

*SERVICE MANUAL*

# A500

OCTOBER, 1990

PN-314981-04

 **Commodore**

*Produced By:*

**Commodore International Spare Parts GmbH  
Braunschweig, West Germany**

***SERVICE MANUAL***

**A500**

**OCTOBER, 1990**

**PN-314981-04**

***INTERNATIONAL EDITION***

COMMODORE "INTERNATIONAL EDITION" SERVICE MANUALS CONTAIN PART NUMBER INFORMATION WHICH MAY VARY ACCORDING TO COUNTRY. SOME PARTS MAY NOT BE AVAILABLE IN ALL COUNTRIES.

**Commodore Business Machines, Inc.**

1200 Wilson Drive, West Chester, Pennsylvania 19380 U.S.A.

Commodore makes no express or implied warranties with regard to the information contained herein. The information is made available solely on an as is basis, and the entire risk as to completeness, reliability, and accuracy is with the user. Commodore shall not be liable for any damages in connection with the use of the information contained herein. The listing of any available replacement part herein does not constitute in any case a recommendation, warranty or guaranty as to quality or suitability of such replacement part. Reproduction or use without express permission, of editorial or pictorial content, in any matter is prohibited.

This manual contains copyrighted and proprietary information. No part of this publication may be reproduced, stored in a retrieval system, or transmitted in any form or by any means, electronic, mechanical, photocopying, recording or otherwise, without the prior written permission of Commodore Electronics Limited.

Copyright © 1990 by Commodore Electronics Limited.  
All rights reserved. Printed in U.S.A.

**SECTION 1**  
**SPECIFICATIONS**

## **Amiga A500 Specifications**

<b>Central Processor</b>	Motorola MC68000
<b>Memory</b>	512K bytes RAM expandable to 1M
<b>Disks</b>	3-1/2 inch double-sided double-density microdisks with 880K bytes formatted storage capacity per disk
<b>Mouse</b>	Mechanical, .13 mm/count (200 counts per inch)
<b>Interfaces</b>	RS-232 serial interface Centronics®-compatible parallel interface External disk interface Mouse/Game controller interface Additional game controller interface Keyboard interface Two audio outputs for stereo sound Memory cartridge interface Expansion interface
<b>Supported Monitors</b>	Analog RGB, digital RGB, monochrome (composite video), and standard televisions
<b>Power Requirements</b>	99 to 121 volts AC 54 to 66 Hz
<b>Temperature Requirements</b>	For operation: 5 to 40 degrees Centigrade (41 to 104 degrees Fahrenheit) For storage: -40 to 60 degrees Centigrade (-40 to 140 degrees Fahrenheit)
<b>Humidity Requirements</b>	20% to 90% relative humidity, non-condensing

**SECTION 2**  
**THEORY OF OPERATIONS**

# Amiga 500 Memory Map

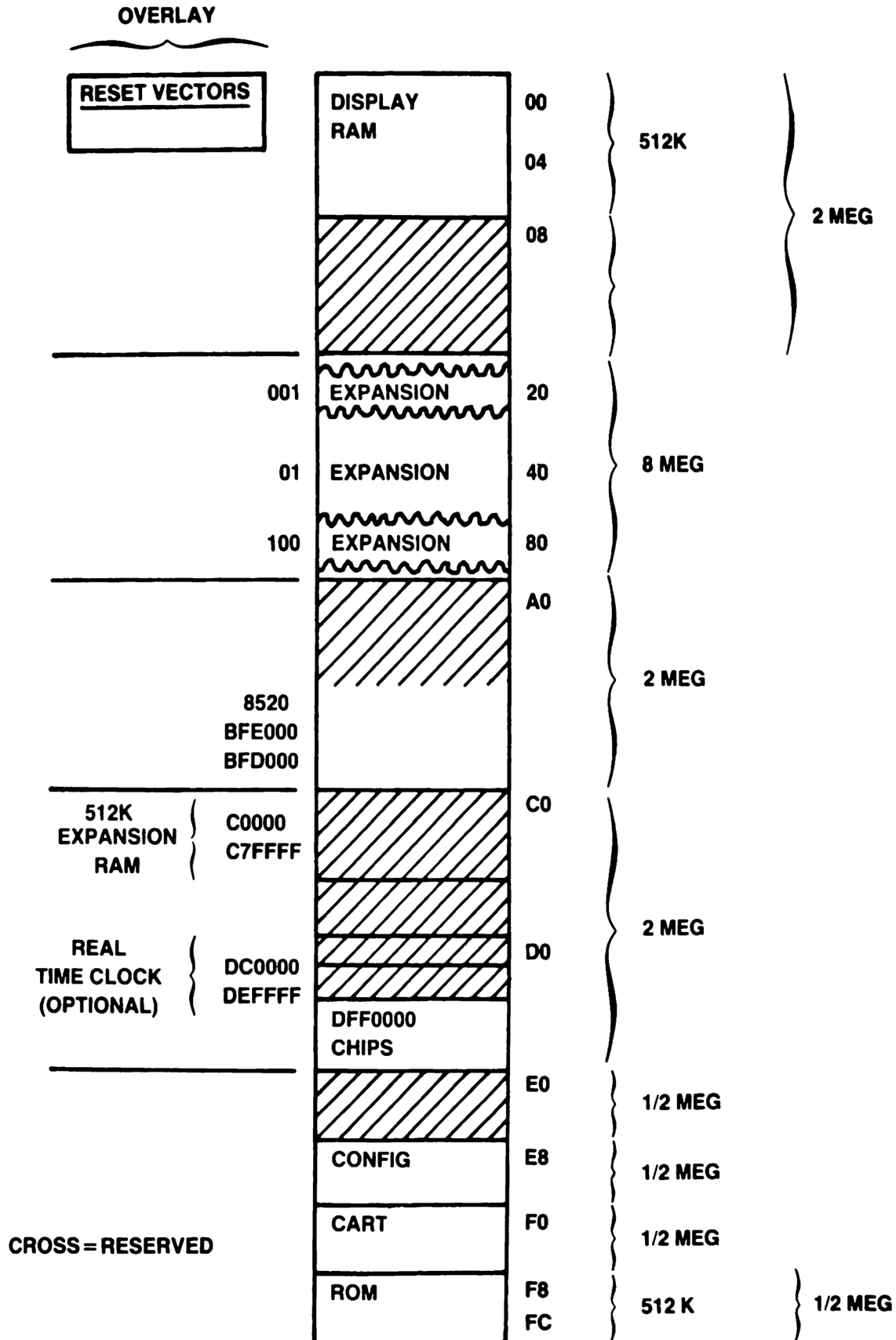

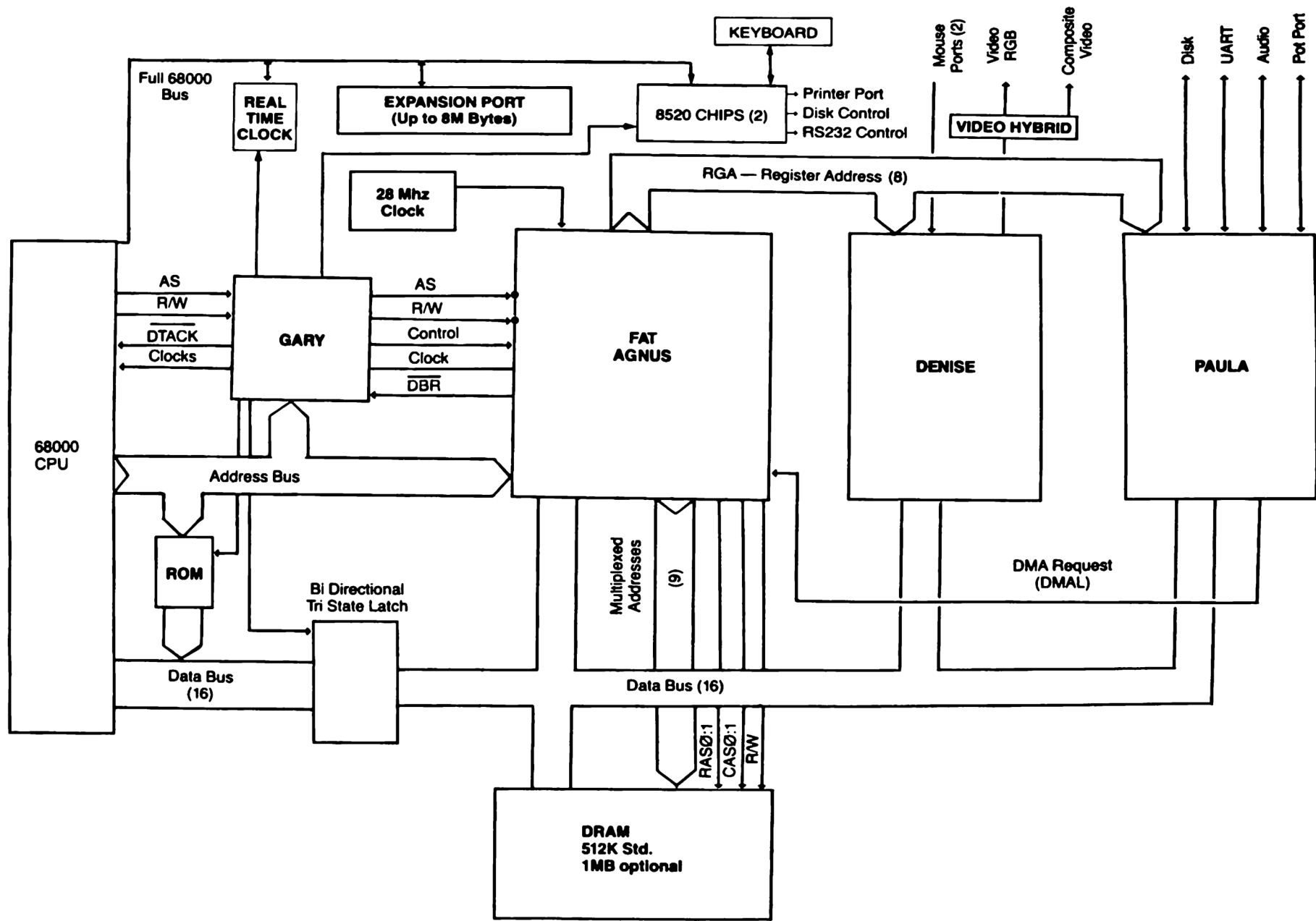

**A500 Block Diagram**

## **Theory of Operation**

The AMIGA computer is a high-performance system with advanced graphics and audio features. The principal hardware features consist of the 68000 microprocessor which runs at 7.2 MHz, 512K RAM, expandable to 1MB, and configurable to 8MB, 2 parallel I/O chips, one control chip (GARY) and 3 custom VLSI chips that provide the unique capabilities for animation, graphics and sound.

### **68000 Microprocessor**

The 68000 is the CPU of the system. All other resources are under software control via control data issued from it. All 3 custom chips have control registers that are written by the 68000.

The 68000 communicates with the rest of the computer via its address bus, data bus and control lines. Notice that in the block diagram the 3 custom chips do not reside directly on the 68000 buses. When the 68000 starts a bus cycle that is intended for the custom chips or the display RAM, the bus control chip detects whether or not the display RAM buses are available. The control chip will not assert the acknowledge signal (/DTACK) back to the 68000 until the display RAM buses are available. Once the 68000 receives /DTACK it completes the bus cycle. Connecting the display RAM buses to the 68000 buses is discussed further in the section on bus control. Because the display RAM is capable of approximately twice the bandwidth of the 68000, the 68000 is usually not delayed by waiting for the display buses to become available.

The 68000 can fetch instructions from:

- Display RAM
- ROM

The 68000 can read and write data directly to:

- Display RAM
- Parallel I/O Chips
- 3 Custom I.C.s
- ROM

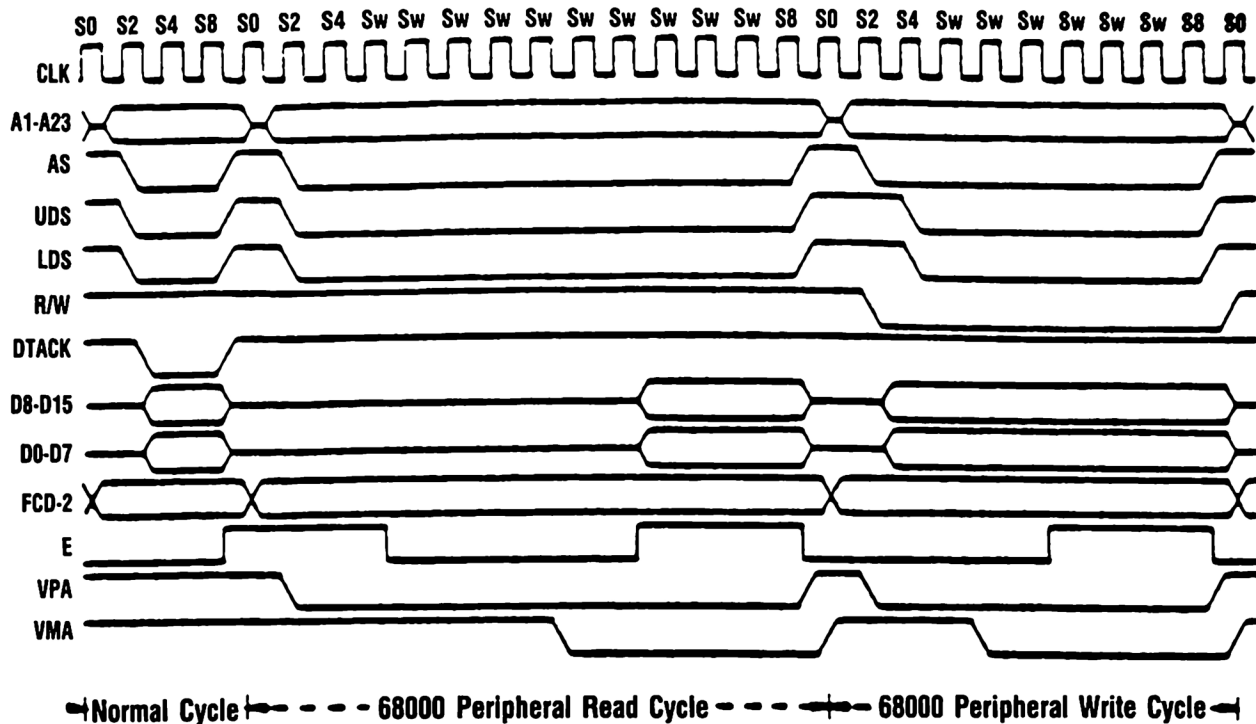

**CPU Machine Cycle**

**SIGNAL SUMMARY**

Signal Name	Mnemonic	Input/Output	Active State	Three State
Address Bus	A1-A23	Output	High	Yes
Data Bus	D0-D15	Input/Output	High	Yes
Address Strobe	$\overline{AS}$	Output	Low	Yes
Read/Write	R/W	Output	Read-High Write-Low	Yes
Upper and Lower Data Strobes	$\overline{UDS}$ , $\overline{LDS}$	Output	Low	Yes
Data Transfer Acknowledge	$\overline{DTACK}$	Input	Low	No
Bus Request	BR	Input	Low	No
Bus Grant	BG	Output	Low	No
Bus Grant Acknowledge	$\overline{BGACK}$	Input	Low	No
Interrupt Priority Level	IPL0, IPL1, IPL2	Input	Low	No
Bus Error	BERR	Input	Low	No
Reset	RESET	Input/Output	Low	No*
Halt	HALT	Input/Output	Low	No*
Enable	E	Output	High	No
Valid Memory Address	$\overline{VMA}$	Output	Low	Yes
Valid Peripheral Address	$\overline{VPA}$	Input	Low	No
Function Code Output	FC0, FC1, FC2	Output	High	Yes
Clock	CLK	Input	High	No
Power Input	Vcc	Input	—	—
Ground	GND	Input	—	—

\*Open Drain  
A0 is internal to 68000

The 68000 transmits data and control to and from the peripherals via the parallel I/O and the 3 custom chips.

7M is the processor clock to the 68000. C1, C3 and CDAC are used to clock the custom chips and determine the timing of signals to the memory arrays.

## **ROM**

The ROM contains the kernel and DOS routines; it is 128K × 16.

## **Parallel I/O**

The 2 multipurpose 8520 I/O chips provide the following:

- I/O to and from the parallel port connector
- Control lines to and from the joystick/mouse ports
- A control line to the front panel LED
- Internal control lines
- Keyboard control lines, clock and data
- Serial port control lines
- Floppy disk interface control lines
- Internal timers

These 2 chips reside on the 68000 buses and are read and written by the 68000.

## **Clocks Generator**

The entire computer board is run synchronously to the 3.57954Mhz color clock (C1). This is accomplished by generating a number of sub-multiple frequencies from our master 28.63636Mhz crystal oscillator. The following are the primary clocks on the board:

<b>Name</b>	<b>Description</b>
C1	The 3.579545Mhz Color Clock
C2	C1 shifted 45 degrees later
C3	C1 shifted 90 degrees later
C4	C1 shifted 135 degrees later
7M	C1 XORed with C3* (7.15909Mhz)
DAC	7M shifted 90 degrees later

7M is the processor clock for the 68000 microprocessor. C1-C4 and DAC are used to clock the custom chips and for determining the timing of signals to the memory arrays.

The above frequencies are true for NTSC Amigas. A PAL Amiga will operate slightly slower, with a main clock of 28.37516Mhz. This is divided down to get  $7M = 7.09379Mhz$  and  $C1 = 3.546895Mhz$ . A special circuit is required to take five fourths of C1 to derive the PAL colorburst frequency of 4.43361875Mhz.

The following clocks are available at the edge connector:

Name	Pin	Description
C3*	14	C3 inverted
CDAC	15	DAC equivalent
C1*	16	C1 inverted

Note that 7M (the processor clock) is not available at the connector; it can be easily generated by:

$$C3^* \text{ XNOR } C1^* = 7M \text{ equivalent}$$

If you need a 14.31818Mhz synchronous clock, you can generate it by:  
 $(7M_{equiv}) \text{ XOR } (CDAC) = 14M \text{ equivalent}$

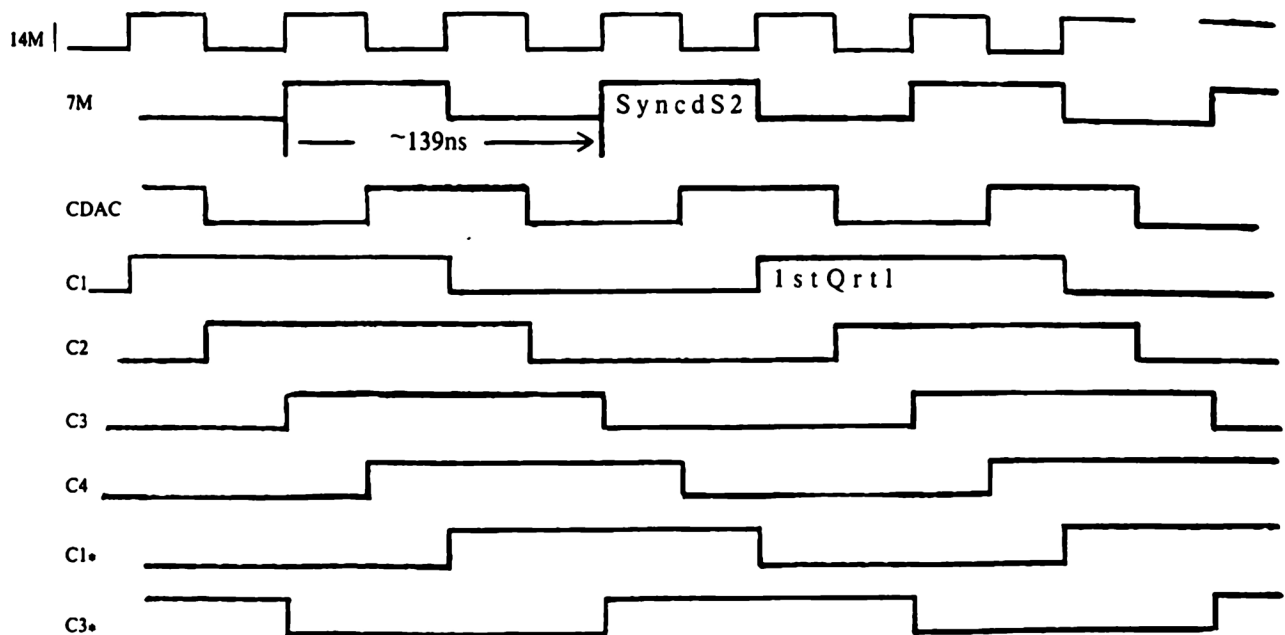

**Amiga System Clocks**

### **The 3 Custom Chips**

The 3 custom chips provide very fast manipulation of graphics and audio data in the display RAM. All the major functions in the chips are DMA driven; that is, streams of data are moved between the custom chips and display RAM under DMA control. These streams of data are acted upon by the custom chips. Fat Agnus, custom chip #1, contains 25 dedicated purpose DMA counters.

The 3 chips have control registers which are usually loaded by the 68000. However, Fat Agnus also has the capability of loading control registers in the other 2 custom chips. When Fat Agnus performs a bus cycle, it outputs a code on the Register Address Bus telling the other 2 chips the nature of the bus cycle. This is necessary because many of the bus cycles provide data to or from the other 2 chips, thus they must cooperate appropriately.

In addition to manipulating data in the display RAM, the custom chips output streams of data to the video output circuits and audio output circuits, and they move data to and from the floppy disks and serial port.

Note that the display RAM buses can be completely isolated from the 68000 buses by Fat Agnus and Data Bus drivers. Thus, Fat Agnus can be performing a bus cycle on the display buses simultaneously with the 68000 performing a bus cycle on its buses. This parallelism increases throughout.

### **Bus Control, Address/Data MUX, Address Driver**

The bus control logic resides in the control chip (GARY) and Fat Agnus. They provide 3 major functions, they:

- Synchronize the 68000 to the current phase of C1
- Arbitrate between the 68000 and Fat Agnus for the display buses
- Generate DRAM timing for the video RAM bus drivers appropriate to the current cycle

Synchronizing the 68000 to C1 is straightforward, since the 68000 is clocked by 7M which is twice the frequency and synchronous to C1. If the 68000 starts a bus cycle in the wrong phase of C1, the bus control chip merely delays /DTACK long enough so that the 68000 will complete the bus cycle in the desired phase relationship to C1. This phase relationship is necessary because the custom chips and the display RAM are clocked by C1.

Arbitration is very simple. Fat Agnus tells the bus control prior to taking the display RAM buses by asserting an input to the control chip (GARY) called /DBR. Whenever Fat Agnus has the display buses and the 68000 wants them, the 68000 is held off by not giving it /DTACK. In this state the 68000 has no effect on the display buses until the bus controller enables the bus drivers.

Fat Agnus generates the DRAM timings and does all address multiplexing. If the 68000 is running a video memory cycle, its addresses are routed through Fat Agnus onto the multiplexed address lines. If the custom chips are running a memory cycle the addresses are routed to the multiplexed address lines from internal address register.

## **Display RAM**

The display RAM is a 512K read/write memory that resides on the RAM address and RAM data buses. It is expandable to 1M bytes by the addition of the RAM expansion module. It is implemented using standard 256K × 1 dynamic RAMs, refreshed by Fat Agnus.

The display RAM is really used for much more than just holding graphics data. It also stores code and data for the 68000.

## **Custom Control Chips**

The Amiga's animation, graphics and sound are produced by three custom chips. Fat Agnus (8370), Denise (8362) and Paula (8364). A fourth custom chip, Gary serves as the control chip. The following pages include pin diagrams, feature lists, and block diagrams for these chips.

## Custom Animation Chip Fat Agnus

### Features:

- Bit Blitter — Uses hardware to move display data — Allows high speed animation — Frees the CPU for other concurrent tasks
- Display Synchronized Coprocessor
- Controls 25 DMA Channels — Allows the disk and sound to operate with minimal CPU intervention
- Generates all system clocks from the 28 Mhz oscillator
- Generates all control signals for the video RAM and expansion RAM card
- Provides the address to the video and expansion RAM multiplexing

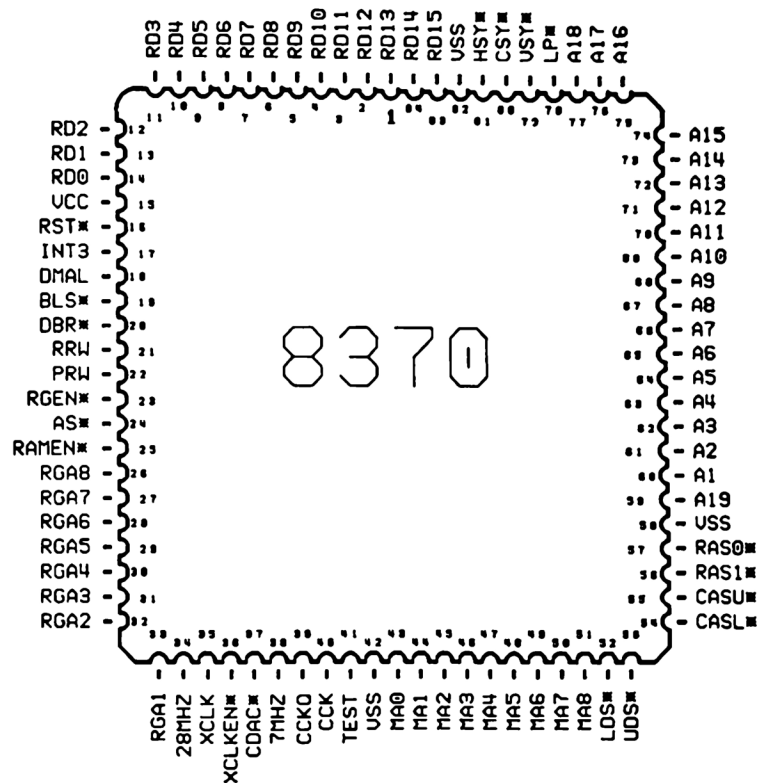

## One Megabyte Agnus use in Commodore A500 Computers.

Commodore Business Machines does not support the One Megabyte addressing feature of the Fat Agnus 8372 IC in A500 Computers.

Regardless of the version of Fat Agnus, all A500's have been factory jumper set to be functionally identical.

8370 Fat Agnus chips are used on rev 5 boards with 256K x 1 DRAMS. 8372 Fat Agnus chips are used on rev 6a boards with 256K x 4 DRAMS. The boards are functionally interchangeable. Each will support 512K of chip RAM and 512K of expansion RAM with an A501 installed.

Enabling the One Megabyte feature, at the customers' request, will void the warranty. Instructions detailing implementation of the One Megabyte addressing have been circulated without Official Approval and Commodore does not assume any liability for damages resulting from this mode of operation in the A500.



## Custom Graphics Chip Denise

**Features:**

- Many different resolutions  
320 × 200 up to 640 × 400
- 4096 colors on a TV or RGB monitor
- Eight re-usable sprite controllers
- 60 or 80 column text
- Same software for all TVs and monitors

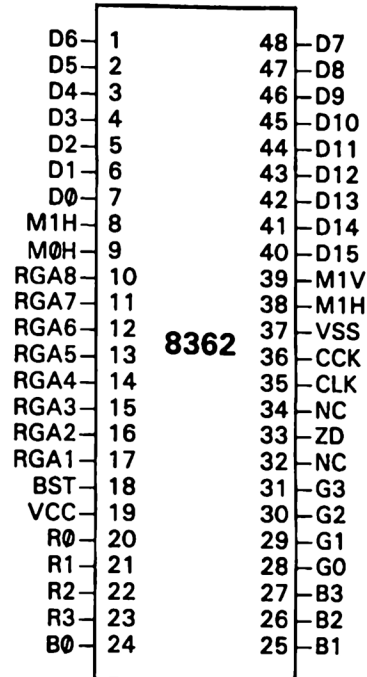

Pin	Name	Description	Type
1-7	D0-D6	Data Bus Lines 0-6	I/O
8	M1H	Mouse 1 Horizontal	I
9	M0H	Mouse 0 Horizontal	I
10-17	RGA1-8	Register Address 1-8	I
18	/BURST	Color Burst	O
19	Vcc	+5 VDC	I
20-23	R0-3	Video Red Bit 0-3	O
24-27	B0-3	Video Blue Bit 0-3	O
28-31	G0-3	Video Green Bit 0-3	O
32	N/C	No Connection	N/C
33	/ZD	Background Indicator	O
34	N/C	No Connection	N/C
35	7M	7.15909 MHz Clock	I
36	CCK	Color Clock	I
37	Vss	Ground	I
38	M0V	Mouse 0 Vertical	I
39	M1V	Mouse 1 Vertical	I
40-48	D7-D15	Data Bus Lines 7-15	I/O

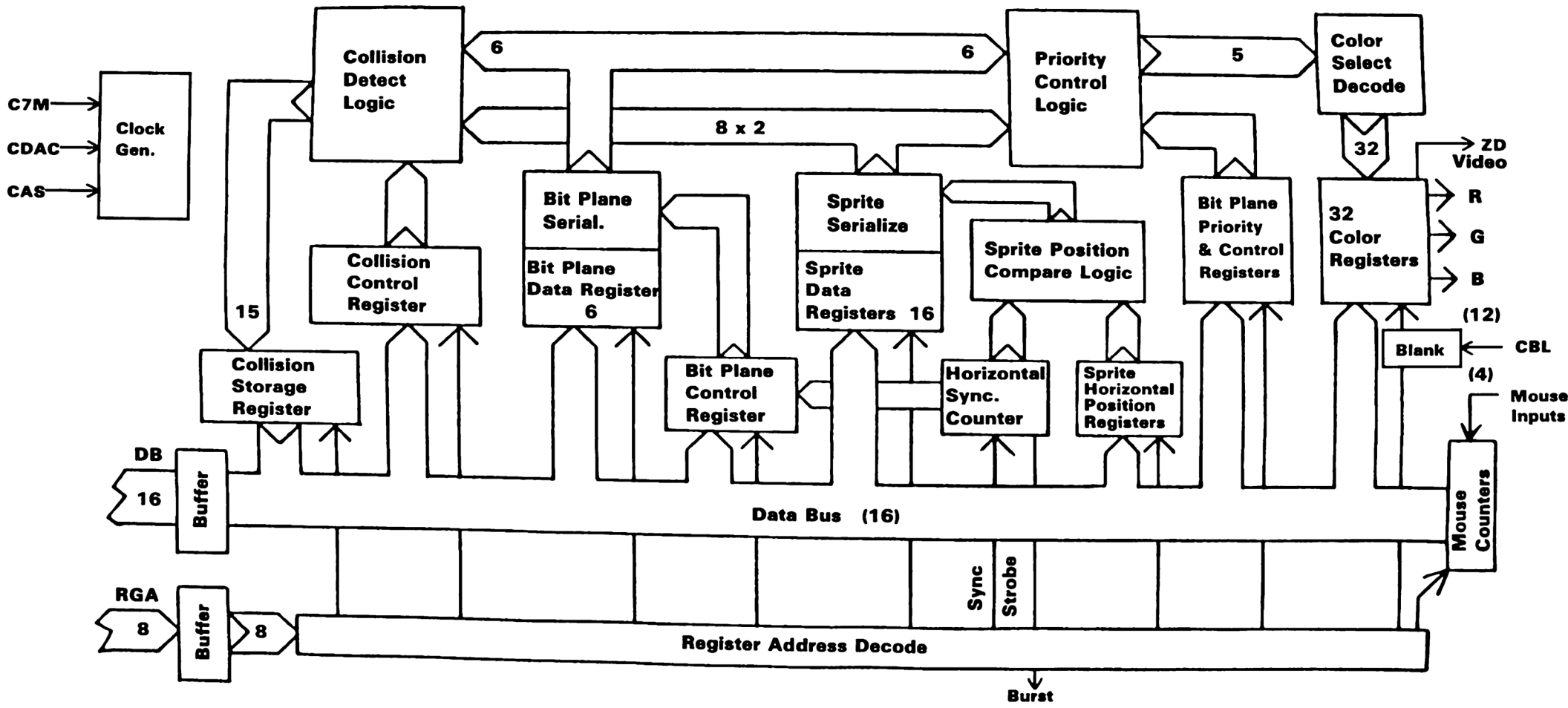

**Denise Block Diagram**

## Custom Sound/Peripherals Chip Paula

### Features:

- Four voices of sound output configured as two stereo channels
- Nine octaves
- Complex waveforms
- Uses both amplitude and frequency modulation
- I/O controls for disk data and controller ports
- Microdisk controller
- Interrupt control system

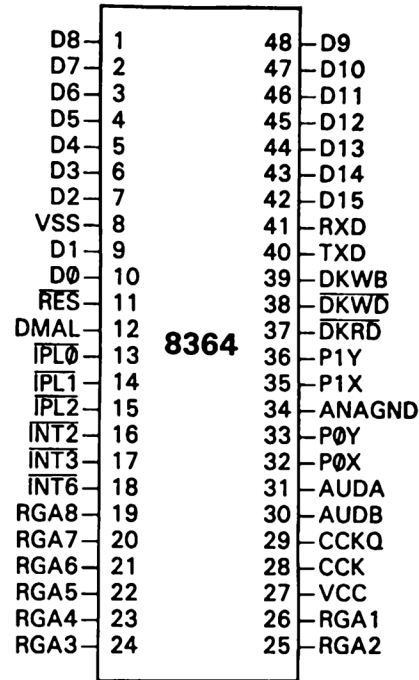

Pin	Name	Description	Type
1-7	D2-D8	Data Bus Lines 2-8	I/O
8	Vss	Ground	I
9,10	D0,D1	Data Bus Lines 0,1	I/O
11	/RES	System Reset	I
12	DMAL	DMA Request Line	O
13-15	/IPL0-2	Interrupt Line 0-2	O
16-18	/INT2,3,6	Interrupt Level 2,3,6	I
19-26	RGA1-8	Register Address 1-8	I
27	Vcc	+5 VDC	I
28	CCK	Color Clock	I
29	CCKQ	Color Clock Delay	I
30	AUSB	Right Audio	O
31	AUDA	Left Audio	O
32	POT0X	Pot 0X	I/O
33	POT0Y	Pot 0Y	I/O
34	VSSANA	Analog Ground	I
35	POT1X	Pot 1X	I/O
36	POT1Y	Pot 1Y	I/O
37	/DKRD	Disk Read Data	I
38	/DKWD	Disk Write Data	O
39	DKWE	Disk Write Enable	O
40	TXD	Serial Transmit Data	O
41	RXD	Serial Receive Data	I
42-48	D9-15	Data Bus Lines 9-15	I/O

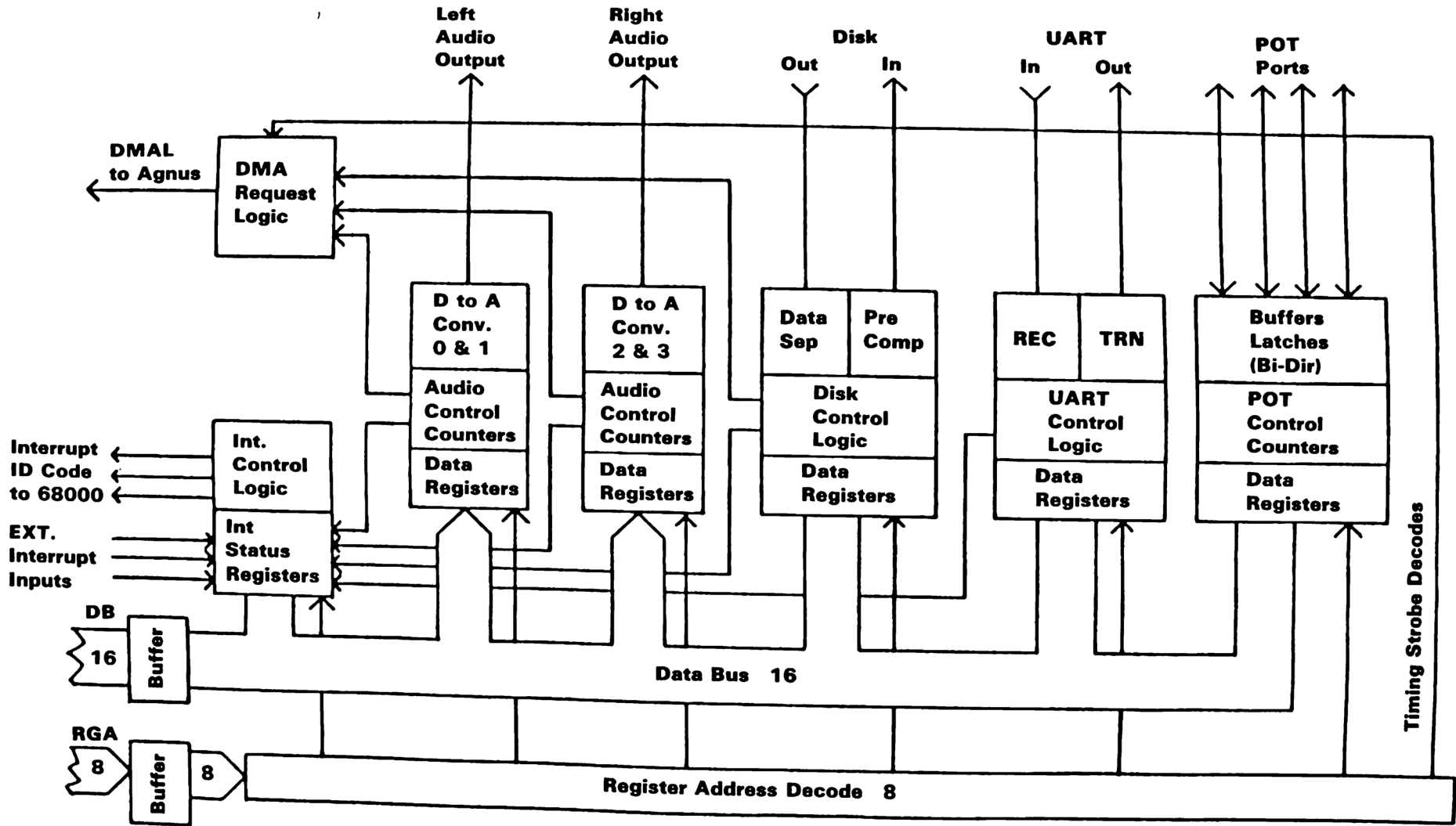

Paula Block Diagram

## Custom Control Chip Gary

**Features:**

- Provides all bus control signals.
- Provides all address decoding.
- Generates the 68000 VPA signal.
- Handles some of the floppy circuitry.
- Provides keyboard reset interface.

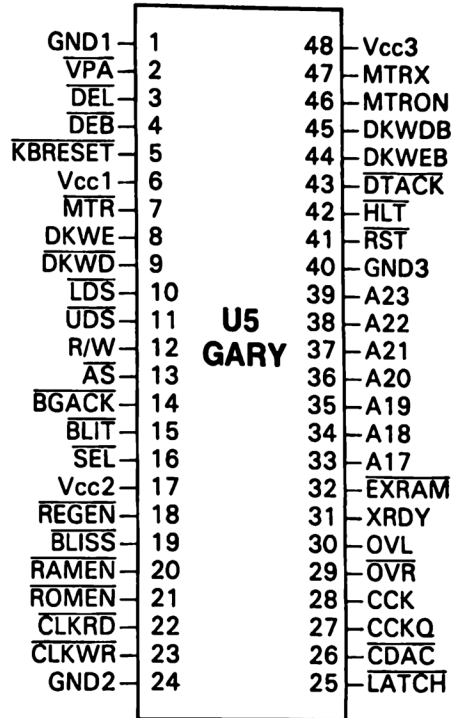

**For signal descriptions see Schematic #312511 (sheet 1 of 9)**

# Gary Block Diagram

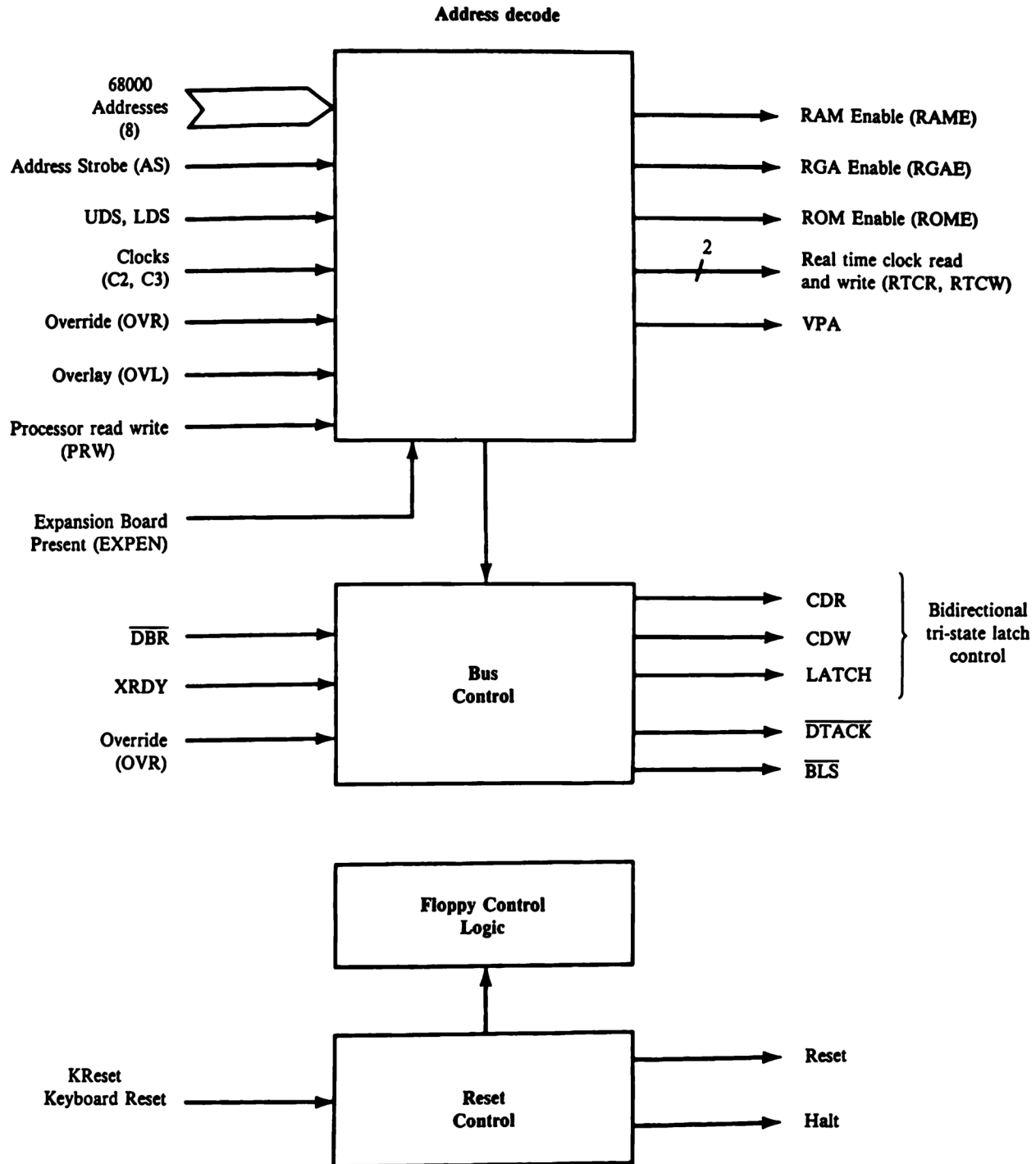

## Complex Interface Adapter

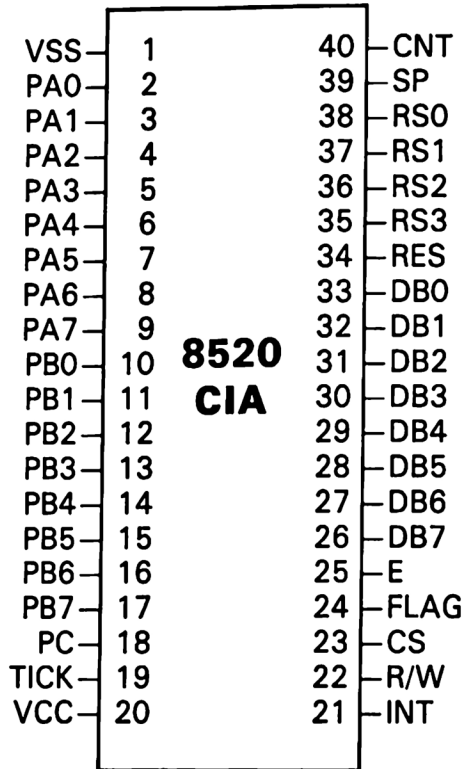

### INTERFACE SIGNALS

#### E Clock Input

Peripheral Clock from 68000 (10 cycles of 7.16Mhz clock — 6 high, 4 low)

#### CS — Chip Select Input

The CS input controls the activity of the 8520. A low level on CS while 02 is high causes the device to respond to signals on the R/W and address (RS) lines. A high on CS prevents these lines from controlling the 8520. The CS line is normally activated (low) at 02 by the appropriate address combination.

#### R/W — Read/Write Input

The R/W signal is normally supplied by the microprocessor and controls the direction of data transfers of the 8520. A high on R/W indicates a read (data transfer out of the 8520), while a low indicates a write (data transfer into the 8520).

#### RS3-RS0 — Address Inputs

The address inputs select the internal registers as described by the Register Map.

#### DB7-DB0 — Data Bus Inputs/Outputs

The eight bit data bus transfers information between the 8520 and the system data bus. These pins are high impedance inputs unless CS is low and R/W and 02 are high, to read the device. During this read, the data bus output buffers are enabled, driving the data from the selected register onto the system data bus.

#### INT — (IRQ) Interrupt Request Output

IRQ is an open drain output normally connected to the processor interrupt input. An external pullup resistor holds the signal high, allowing multiple IRQ-outputs to be connected together. The IRQ output is normally off (high impedance) and is activated low as indicated in the functional description.

#### RES — Reset Input

A low on the RES pin resets all internal registers. The port pins are set as inputs and port registers to zero (although a read of the ports will return all highs because of passive pullups). The timer control registers are set to zero and the timer latches to all ones. All other registers are reset to zero.

REGISTER MAP

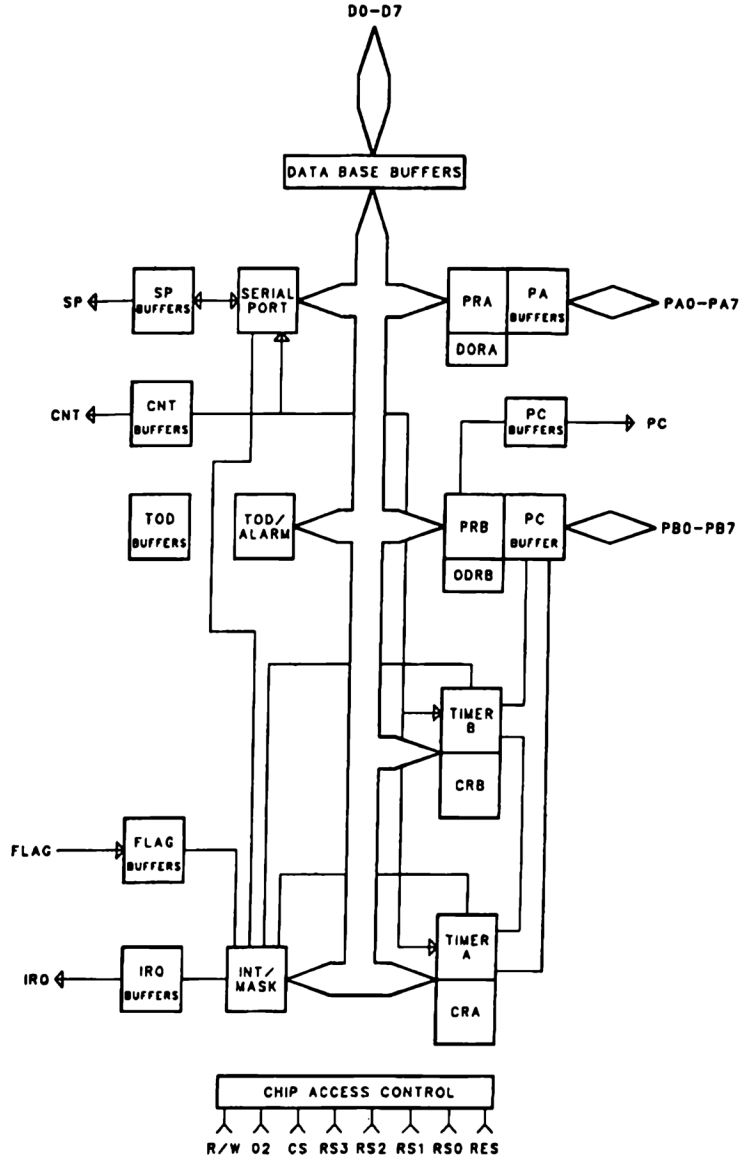

RS3	RS2	RS1	RS0	REG	
0	0	0	0	0	PRA Peripheral Data Reg. A
0	0	0	1	1	PRB Peripheral Data Reg. B
0	0	1	0	2	DDRA Data Direction Reg. A
0	0	1	1	3	DDRB Data Direction Reg. B
0	1	0	0	4	TA LO Timer A Low Register
0	1	0	1	5	TA HI Timer A High Register
0	1	1	0	6	TB LO Timer B Low Register
0	1	1	1	7	TB HI Timer B High Register
1	0	0	0	8	Event LSB
1	0	0	1	9	Event 8-15
1	0	1	0	A	Event MSB
1	0	1	1	B	No Connect
1	1	0	0	C	SDR Serial Data Register
1	1	0	1	D	ICR Interrupt Control Register
1	1	1	0	E	CRA Control Register A
1	1	1	1	F	CRB Control Register B

**FUNCTION DESCRIPTION**

**I/O Ports (PRA, PRB, DDRA, DDRB)**

Ports A and B each consist of an 8-bit Peripheral Data Register (PR) and an 8-bit Data Direction Register (DDR). If a bit in the DDR is set to the corresponding bit in the PR it is an output. If a DDR bit is set to zero, the corresponding PR bit is defined as an input. On a READ, the PR reflects the information present on the actual port pins (PA0-PA7, PBO-PB7) for both input and output bits. Port A has both passive and active pullup devices, providing both CMOS and TTL compatibility. It can drive 2 TTL loads. Port B has only passive pullup device and has a much higher current-sinking capability.

**Handshaking**

Handshaking on data transfers can be accomplished using the PC output pin and the FLAG input pin. PC will go low on the 3rd cycle after a PORT B access. This signal can be used to indicate "data ready" at PORT B or "data accepted" from PORT B. Handshaking on a 16-bit data transfers (using both PORT A and PORT B) is possible by always reading or writing PORT A first. FLAG is a negative edge sensitive input which can be used for receiving the PC output from another 8520 or as a general purpose interrupt input. Any negative transition on FLAG will set the FLAG interrupt bit.

Reg	Name	D7	D6	D5	D4	D3	D2	D1	D0
0	PRA	PA7	PA6	PA5	PA4	PA3	PA2	PA1	PA0
1	PPB	PB7	PB6	PB5	PB4	PB3	PB2	PB1	PB0
2	DDRA	DPA7	DPA6	DPA5	DPA4	DPA3	DPA2	DPA1	DPA0
3	DDRB	DPB7	DPB6	DPB5	DPB4	DPB3	DPB2	DPB1	DPB0

**Interval Timers (Timer A, Timer B)**

Each interval timer consists of a 16-bit read-only Timer Counter and a 16-bit write-only Timer Latch. Data written to the timer is latched in the Timer Latch, while data read from the timer are the present contents of the Timer Counter. The timers can be used independently or linked for extended operations. The various timer modes allow generation of long time delays, variable width pulses, pulse trains and variable frequency waveforms. Utilizing the CNT input, the timers can count external pulses or measure frequency, pulse width and delay times of external signals. Each timer has an associated control register, providing independent control of the following functions.

**Start/Stop**

A control bit allows the timer to be started or stopped by the microprocessor at any time.

**PB On/Off**

A control bit allows the timer output to appear on a PORT B output line (PB6 for TIMER A and PB7 for TIMER B). This function overrides the DDRB control bit and forces the appropriate PB line to an output.

**Toggle/Pulse**

A control bit selects the output applied to PORT B. On every timer underflow the output can either toggle or generate a single positive pulse of one cycle duration. The toggle output is set high whenever the timer is started and is set low by RES.

**One-Shot/Continuous**

A control bit selects either timer mode. In one-shot mode, the timer will count down from the latched value to zero, generate an interrupt, reload the latched value, then stop. In continuous mode, the timer will count from the latched value to zero, generate an interrupt, reload the latched value and repeat the procedure continuously. In one-shot mode: a write to Timer High (registers 5 for TIMER A, 7 for TIMER B) will transfer the timer latch to the counter and initiate counting regardless of the start bit.

**Force Load**

A strobe bit allows the timer latch to be loaded into the timer counter at any time, whether the timer is running or not.

**Input Mode**

Control bits allow selection of the clock used to decrement the timer. TIMER A can count 02 pulses or external pulses applied to the CNT pin. TIMER B can count 02 pulses, external CNT pulses, TIMER A underflow pulses or TIMER A underflow pulses while the CNT pin is held high.

The timer latch is loaded into the timer on any timer underflow, on a force load or following a write to the high byte of the prescaler while the timer is stopped. If the timer is running, a write to the high byte will load the timer latch, but not reload the counter.

**READ (TIMER)**

REG	Name								
4	TA LO	TAL7	TAL6	TAL5	TAL4	TAL3	TAL2	TAL1	TAL0
5	TA HI	TAH7	TAH6	TAH5	TAH4	TAH3	TAH2	TAH1	TAH0
6	TB LO	TBL7	TBL6	TBL5	TBL4	TBL3	TBL2	TBL1	TBL0
7	TB HI	TBH7	TBH6	TBH5	TBH4	TBH3	TBH2	TBH1	TBH0

**WRITE (PRESCALER)**

REG	Name								
4	TA LO	PAL7	PAL6	PAL5	PAL4	PAL3	PAL2	PAL1	PAL0
5	TA HI	PAH7	PAH6	PAH5	PAH4	PAH3	PAH2	PAH1	PAH0
6	TB LO	PBL7	PBL6	PBL5	PBL4	PBL3	PBL2	PBL1	PBL0
7	TB HI	PBH7	PBH6	PBH5	PBH4	PBH3	PBH2	PBH1	PBH0

**TOD (TICK)**

TOD consists of a 24 bit binary counter. Positive edge transitions on this pin cause the binary counter to increment. The TOD pin has a passive pull-up on it. A programmable ALARM is provide for generating an interrupt at a desired time. The ALARM registers are located at the same addresses as the corresponding TOD register. Access to the ALARM is governed by a Control Register bit. The ALARM is write-only; any read of a TOD address will read time regardless of the state of the ALARM access bit.

A specific sequence of events must be followed for proper setting and reading of TOD. TOD is automatically stopped whenever a write to the register occurs. The clock will not start again until after a write to the LSB Event Register. This assures TOD will always start at the desired time. Since a carry from one stage to the next can occur at any time with respect to a read operation, a latching function is include to keep all Time of Day information constant during a read sequence. All TOD registers latch on a read of MSB event and remain latched until after a read of LSB Event. The TOD clock continues to count when the output registers are latched. If only one register is to be read, there is no carry problem and the register can be read "on the fly", provided that any read of MSB Event is followed by a read of LSB Event to disable the latching.

**READ**

REG	Name	E7	E6	E5	E4	E3	E2	E1	E0
8	LSB Event								
9	Event 8-15	E15	E14	E13	E12	E11	E10	E9	E8
A	MSB Event	E23	E22	E21	E20	E19	E18	E17	E16

**WRITE**

CRB7=0

CRB7=1 ALARM

(SAME FORMAT AS READ)

**Serial Port (SDR)**

The serial port is a buffered, 8-bit synchronous shift register system. A control bit selects input or output mode. In input mode, data on the SP pin is shifted into the shift register on the rising edge of the signal applied to the CNT pin. After 8 CNT pulses, the data in the shift register is dumped into the Serial Data Register and an interrupt is generated. In the output mode, TIMER A is used for the baud rate generator. Data is shifted out on the SP pin at 1/2 the underflow rate of TIMER A. The maximum baud rate possible is 02 divided by 6, but the maximum useable baud rate will be determined by line loading and the speed at which the receiver responds to input data. Transmission will start following a write to the Serial Data Register (provided TIMER A is running and in continuous mode). The clock signal derived from TIMER A appears as an output on the CNT pin. The data in the Serial Data Register will be loaded into the shift register then shift out to the SP pin when a CNT pulse occurs. Data shifted out becomes valid on the falling edge of CNT and remains valid until the next falling edge. After 8 CNT pulses, an interrupt is generated to indicate more data can be sent. If the Serial Data Register was loaded with new information prior to this interrupt, the new data will automatically be loaded into the shift register and transmission will be continuous. If no further data is to be transmitted, after the 8th CNT pulse, CNT will return high and SP will remain at the level of the last data bit transmitted. SDR data is shifted out MSB first and serial input data should also appear in this format.

The bidirectional capability of the Serial Port and CNT clock allows several devices to be connected to a common serial communication bus on which one acts as a master, sourcing data and shift clock, while all other chips act as slaves. Both CNT and SP outputs are open drain, with passive pull-ups, to allow such a common bus. Protocol for slave/master selection can be transmitted over the serial bus, or via dedicated handshaking lines.

REG	Name	S7	S6	S5	S4	S3	S2	S1	S0
C	SDR								

**Interrupt Control (ICR)**

There are five sources of interrupts on the 8520: underflow from TIMER A, underflow from TIMER B, TOD ALARM, Serial Port full/empty and FLAG. A single register provides masking and interrupt information. The Interrupt Control Register consists of a write-only MASK register and a read-only DATA register. Any interrupt which is enabled by the MASK register will set the IR bit (MSB) of the DATA register and bring the IRQ pin low. In a multi-chip system, the IR bit can be polled to detect which chip has generated an interrupt request.

The interrupt DATA register is cleared and the IRQ line returns high following a read of the DATA register. Since each interrupt sets an interrupt bit regardless of the MASK, and each interrupt bit can be selectively masked to prevent the generation of a processor interrupt, it is possible to intermix polled interrupts with true interrupts. However, polling the IR bit will cause the DATA register to clear, therefore, it is up to the user to preserve the information contained in the DATA register if any polled interrupts were present.

The MASK register provides convenient control of individual mask bits. When writing to the MASK register, if bit 7 (SET/CLEAR) of the data written is a ZERO, any mask bit written with a one will be cleared, while those mask bits written with a zero will be unaffected. If bit 7 of the data written is a ONE, any mask bit written with a one will be set, while those mask bits written with a zero will be unaffected. In order for an interrupt flag to set IR and generate an Interrupt Request, corresponding MASK bit must be set.

**READ (INT DATA)**

REG	Name	IR	0	0	FLG	SP	ALRM	TB	TA
D	IRC								

**WRITE (INT MASK)**

REG	Name	S/C	X	X	FLG	SP	ALRM	TB	TA
D	IRC								

**Control Registers**

There are two control registers in the 8520: CRA and CRB. CRA is associated with TIMER A and CRB is associated with TIMER B.

**CRA:**

BIT	NAME	FUNCTION
0	START	1 = START TIMER A, 0 = STOP TIMER A. This bit is automatically reset when underflow occurs during one-shot mode.
1	PBON	1 = TIMER A output appears on PB6, 0 = PB6 normal operation.
2	OUTMODE	1 = TOGGLE, 0 = PULSE
3	RUNMODE	1 = ONE-SHOT, 0 = CONTINUOUS
4	LOAD	1 = FORCE LOAD (this is a STROBE input, there is no data storage, bit 4 will always read back a zero and writing a zero has no effect.
5	INMODE	1 = TIMER A counts positive CNT transitions, 0 = TIMER A counts 02 pulses.
6	SPMODE	1 = SERIAL PORT output (CNT sources shift clock). 0 = SERIAL PORT input (external shift clock required).
7	TODIN	1 = 50 Hz clock required on TOD pin for accurate time. 0 = 60 Hz clock required on TOD pin for accurate time.

**CRB:**

BIT	NAME	FUNCTION															
		(Bits CRB0-CRB4 are identical to CRA0-CRA4 for TIMER B with the exception that bit 1 controls the output of TIMER B on PB7).															
5.6	INMODE	Bits CRB5 and CRB6 select one of four input modes for TIMER B as:															
		<table border="1"> <thead> <tr> <th>CRB6</th> <th>CRB5</th> <th>FUNCTION</th> </tr> </thead> <tbody> <tr> <td>0</td> <td>0</td> <td>TIMER B counts 02 pulses.</td> </tr> <tr> <td>0</td> <td>1</td> <td>TIMER B counts positive CNT transitions.</td> </tr> <tr> <td>1</td> <td>0</td> <td>TIMER B counts TIMER A underflow pulses.</td> </tr> <tr> <td>1</td> <td>1</td> <td>TIMER B counts TIMER A underflow pulses while CNT is high.</td> </tr> </tbody> </table>	CRB6	CRB5	FUNCTION	0	0	TIMER B counts 02 pulses.	0	1	TIMER B counts positive CNT transitions.	1	0	TIMER B counts TIMER A underflow pulses.	1	1	TIMER B counts TIMER A underflow pulses while CNT is high.
CRB6	CRB5	FUNCTION															
0	0	TIMER B counts 02 pulses.															
0	1	TIMER B counts positive CNT transitions.															
1	0	TIMER B counts TIMER A underflow pulses.															
1	1	TIMER B counts TIMER A underflow pulses while CNT is high.															
7	ALARM	1 = writing to TOD registers set ALARM, 0 = writing to TOD registers sets TOD clock.															

**ELECTRICAL PARAMETERS**

**Absolute Maximum Ratings**

Stresses above those listed may cause permanent damage to the circuit. Functional operation of the device at these or any conditions other than those indicated in the operating conditions of the specification is not implied. Exposure to the maximum ratings for extended periods may adversely affect device reliability.

Supply Voltage	Vcc	-0.3V to 7.0V	Operating Temp.	Top	0°C to 70°C
Input/Output Voltage	Vin	-0.3V to 7.0V	Storage Temp.	Tstg	-55°C to 150°C

\*All inputs contain protection circuitry to prevent damage due to high static discharges. Care should be exercised to prevent unnecessary application of voltages in excess of the allowable limits.

**ELECTRICAL CHARACTERISTICS (VCC +/- 5%, VSS = 0v, TA = 0.70 C)**

CHARACTERISTICS	SYMBOL	MIN.	TYP.	MAX.	UNIT
Input High Voltage	Vih	+2.4	—	Vcc	V
Input Low Voltage	Vil	-3.0	—	+0.8	V
Input leakage current VIN = VSS + 5V (TOD, R/W, 02, RES, RS0-RS3, CS)	Iin	—	1.0	2.5	µA
PA0-7, PB0-7, TOD, FLAG, SP, CNT	Rpi	3.1	5.0	—	KΩ
Output leakage current for High Impedance State VIN = 4V to 2.4V (DB0-DB7, IRQ)	Itsi	—	±1.0	±10.0	µA
Output High Voltage VCC = MIN, LOAD < -200µA (PA0-PA7, DB0-DB7)	Voh	+2.4	—	Vcc	V
Output Low Voltage (PA0-PA7, DB0-DB7) VCC = MIN, LOAD < 3.2µA	Vol	—	—	+0.40	V
Output High Current (sourcing) VOH > 2.4V (PA0-PA7, DB0-DB7)	Ioh	-200	-1000	—	µA
Output Low Current (sinking) VOL < .4V (PA0-PA7, DB0-DB7)	Iol	3.2	—	—	µA
Output Low Current (sinking) VOL < .4V (PC, PB0-PB7)	Iol	13.0	—	—	µA
Input Capacitance	Cin	—	7	10	pf
Output Capacitance	Cout	—	7	10	pf
Power Supply Current	Icc	—	70	100	µA

TIMING DIAGRAMS

WRITE TIMING DIAGRAM

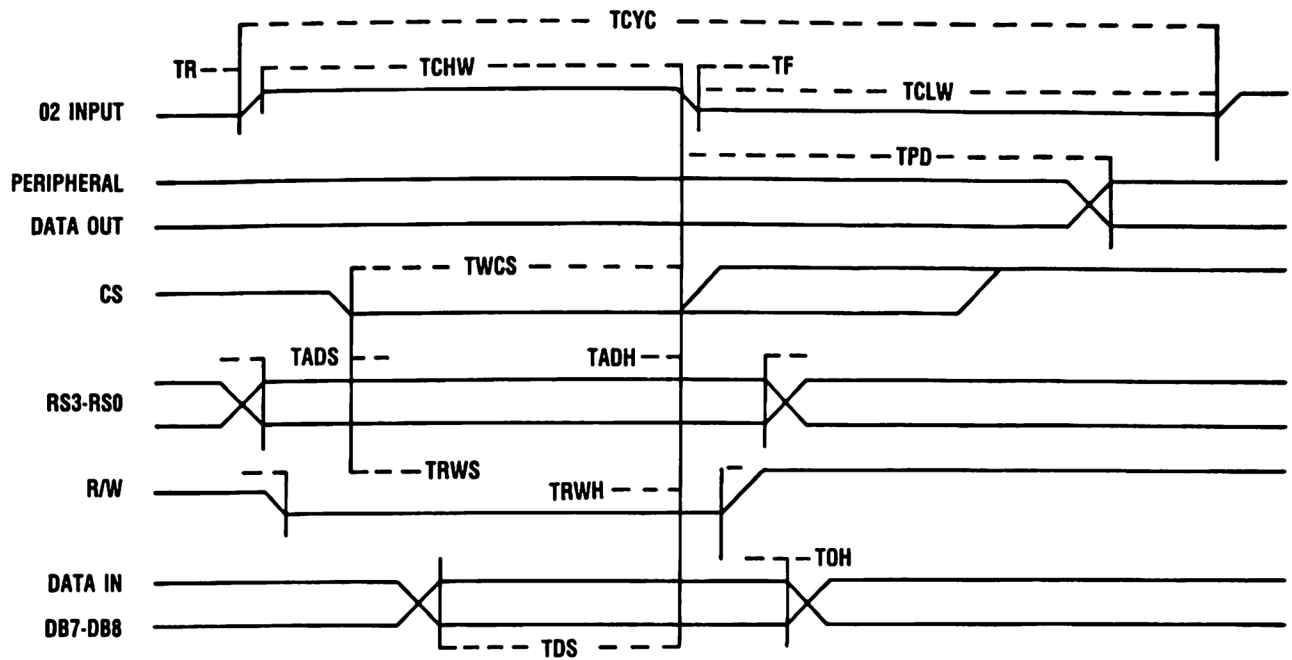

READ TIMING DIAGRAM

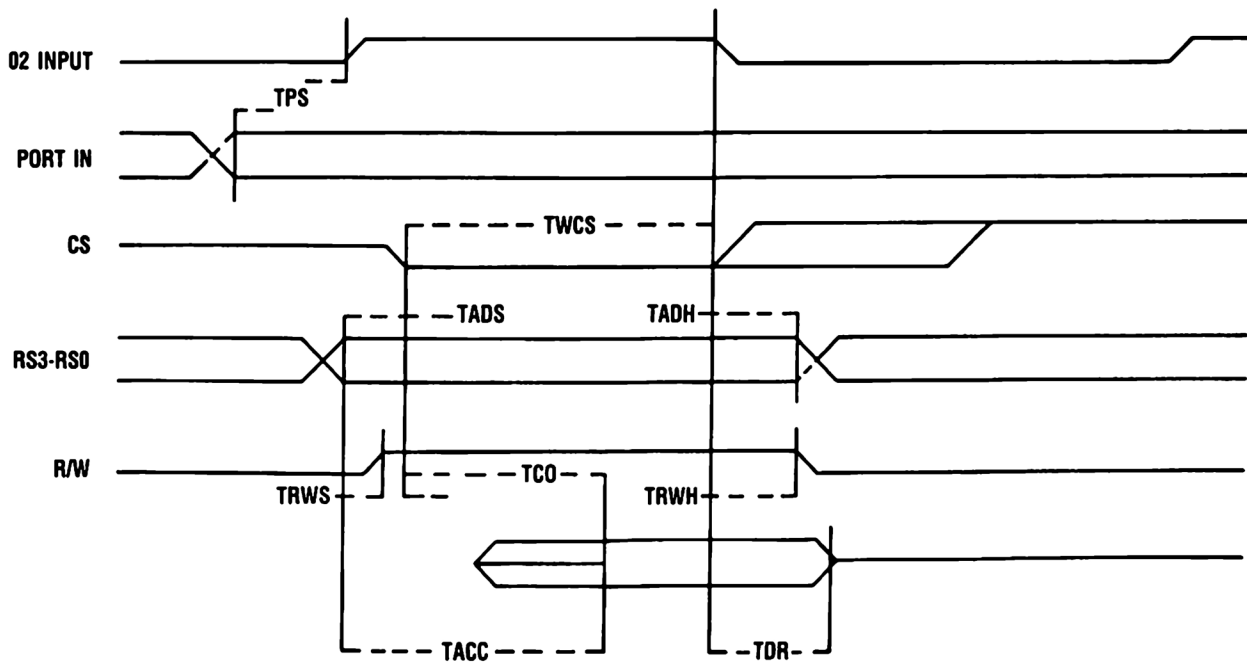

**2.2 Timing Characteristics**

SYMBOL	CHARACTERISTIC	1MHZ	
		MIN	MAX
<b>02 CLOCK</b>			
TCYC	Cycle Time	1000	10,000
TR, TF	Rise and Fall Time	—	25
TCHW	Clock Pulse Width (High)	440	5,000
TCLW	Clock Pulse Width (Low)	440	5,000
<b>WRITE CYCLE</b>			
TPD	Output Delay From 02	—	960
TWCS	CS low while 02 high	280	—
TADS	Address setup time	58	—
TADH	Address hold time	10	—
TRWS	R/W setup time	58	—
TRWH	R/W hold time	10	—
TDS	Data bus setup time	200	—
TDH	Data bus hold time	15	—
<b>READ CYCLE</b>			
TPS	Port setup time	300	—
TWCS(2)	CS low while 02 high	280	—
TADS	Address setup time	58	—
TADH	Address hold time	10	—
TRWS	R/W setup time	58	—
TRWH	R/W hold time	10	—
TACC	Data access from RS3-RS0	—	300
TCO(3)	Data access from CS	—	240
TDR	Data release time	50	—

\*See diagram on page 23 for timing relationships.

**\*NOTES:**

1. All timings are referenced from VIL max and VIH min on inputs and VOL max and VOH min on outputs.
2. TWCS is measured from the later of 02 high or CS low. CS must be low at least until the end of 02 high.
3. TCO is measured from the later of 02 high or CS low. Valid data is available only after the later of TACC or TCO.

**SECTION 3**  
**TROUBLESHOOTING**

**A500/A2000 SYSTEM TEST**

System Test is an auto-boot diskette. Once booted its own cli window will open. Type the commands listed below in order to run each test.

- KEYTEST**
  - Full keyboard test
  - press all keys to confirm proper operation
  - click left mouse button in upper left corner to EXIT
  
- KB**
  - Keyboard matrix test
  - pressing the keys indicated by the program will test the matrix and seven dedicated key functions
  
- SCREENTEST**
  - Screentest is low resolution graphic screen made up of 6 bit planes. Used to test RGB linearity and HALF BRIGHTS.
  - screentest will display a RGB COLOR BAR scale and a 16 level gray scale in both normal and half bright mode. Normal scales are on top.
  - Press space bar to EXIT screen.
  
- SHOW.HIRES.TEST**
  - Hires.Test is a 4 bit plane high resolution 640 by 400 screen that displays NTSC color bars, 8 level gray scales, horizontal resolution lines, and an interlace test.
  - Press space bar to EXIT screen.
  
- SHOW BALLOON**
  - Balloon is a 6 bit plane hold and modify picture used to verify proper HAM decoding.
  - This will test for a bad Agnus or Denise chip.
  - Press space bar to EXIT screen.
  
- CUBEROTE**
  - Cuberote is an animated cube whose speed and direction is controlled by the mouse X-Y position. The cube is blue with shading of three visible sides. Cuberote uses double buffering for a smooth animation. Direct manipulation of the Copper List permits the display of 16 shades blue while only using 2 bit planes.
  - Click left mouse button in upper left corner to EXIT screen.
  
- SYSTEST**
  - Systest will run the following test Realtime clock, Blit, Chip/Fast Ram Sprites/Bliter, and Disk I/O.
  - Reboot computer to EXIT program.

Type the following for customizing systest.

SYSTEST 246d	; A500 NO A501	PCB
SYSTEST 2436cd	; A500 WITH A501 OR A2000	PCB
SYSTEST 1245679d	; A500 NO A501	BURN-IN
SYSTEST 12345679cd	; A500 WITH A501 OR A2000	BURN-IN
SYSTEST 12345678d	; A500 NO A501	AGING
SYSTEST 12345678cd	; A500 WITH A501 OR A2000	AGING

**A500/A2000 SYSTEM TEST (Continued)**

The system test may also be customized. Type the word SYSTEST then select any of the numeric alpha characters listed below.

- |          |                                       |  |
|----------|---------------------------------------|--|
| <b>1</b> | <b><i>_LOOP</i></b>                   | Enable endless loop. This will test the real time clock and the blit only once. Then cycle through any of the selected test.   |
| <b>2</b> | <b><i>_BLIT</i></b>                   | This will run BOXER as a background task for loading.  |
| <b>3</b> | <b><i>_EXTERNAL (FAST) RAM</i></b>    | This will test ram at \$C00,000 and \$200,000 to \$9FF,FFF if found. If Fast ram is not detected program will pass but say FAST RAM NOT FOUND.   |
| <b>4</b> | <b><i>_EXTERNAL (CHIP) RAM</i></b>    | This is the same as FAST RAM test except that it test from \$0 to \$800,000.   |
| <b>5</b> | <b><i>_EXTENDED RAM TEST</i></b>      | This is an expanded version of Fast Ram. Along with unique address and refresh various bit patterns are used. These are All Zeros, All Ones, All A's and All 5's.                            |
| <b>6</b> | <b><i>_DISK</i></b>                   | In order to test the disk I/O. Tracks 2 and 8 will first be formatted. Upon successes \$6DB6 will be written and verified from tracks 2 and 8.   |
| <b>7</b> | <b><i>_EXTENDED DISK</i></b>          | For Extended Disk all ONES, ALL ZEROS, \$AAAA and \$5555 are used.   |
| <b>8</b> | <b><i>_EXTRA DISK SEEK</i></b>        | During PCB and Burn-in testing this will seek only at a minimum. However during Aging test it will use maximum seeking.  |
| <b>9</b> | <b><i>_DISK CYCLE</i></b>             | This will test disk every 8 cycles if Loop test is also selected.  |
| <b>a</b> | <b><i>_NO AUDIO</i></b>               | Disable Audio test.  |
| <b>b</b> | <b><i>_NO SPRITES</i></b>             | Disable Sprite test.   |
| <b>c</b> | <b><i>_CLOCK CHIP</i></b>             | This will test the real time clock chip.   |
| <b>d</b> | <b><i>_DISPLAY GRAPHICS CLOCK</i></b> | Displaying the graphics clock will test bliter indicating a bad agnus chip if display is corrupt.  |
| <b>f</b> | <b><i>_BLITER LINE DRAW</i></b>       | This will test for extraneous bit set. Previously visual inspection of the graphics clock was used to test bliter. However now the line draw feature of agnus is tested through the program. |

**AMIGA 1.3 STARTUP SEQUENCE — OVERVIEW**

- 1 - DELAY 1/3 SECOND (LET HARDWARE SETTLE)
- 2 - JUMP TO ROM CODE IN DIAG CART (IF FOUND)
- 3 - DISABLE/CLEAR ALL INTERRUPTS & DMA'S
- 4 - TURN ON SCREEN
- 5 - DISPLAY DARK GREY SCREEN — HARDWARE OK
- 6 - CHECKSUM ROM — IF BAD DISPLAY RED SCREEN
- 7 - SET UP TEMPORARY EXCEPTION PROCESSING — IF SPURIOUS EXCEPTION OCCUR, DISPLAY YELLOW SCREEN
- 8 - CONFIGURE LOCAL MEMORY (CHECK BOUNDARIES, SIZE) IF PROBLEM, DISPLAY GREEN SCREEN
- 9 - CHECK SOME CUSTOM IC REGISTERS — IF FAILURE, DISPLAY BLUE SCREEN
- 10 - RESTORE SCREEN — CHANGE TO LIGHT GREY = SOFTWARE OK

**A500 SYSTEM TROUBLESHOOTING**

**SECTION 1 — BASIC PRELIMINARY CHECKS**

There are a few basic checks which must be made on the A500 when troubleshooting a SYSTEM THAT DISPLAYS NO VIDEO ON POWER UP IN ANY AVAILABLE VIDEO MODE. There are several things which may cause this symptom but these BASIC SIGNALS MUST BE PRESENT in order for the system to operate. If all these Basic Checks seem correct, more Advanced Checks are covered in SECTIONS 2 THRU 3.

All signals must be taken with power applied to the system unless specified.

A (P) preceding the step number indicates signals which must be measured as power is applied to the system.

ALL MEASUREMENTS ARE WITHIN A  $\pm 10\%$  TOLERANCE  
 ALL READINGS MUST BE TAKEN WITH AN OSCILLOSCOPE  
 (P) INDICATES SIGNALS WHICH MUST BE MEASURED ON SYSTEM POWER UP

- STEP 1 Measure the voltage on pin 1 (right pin) on connector CN12  
 • Result = +5 VDC Level Continue to Step 2
- STEP 2 Measure the voltage on pin 4 (left pin) on connector CN12  
 • Result = +12 VDC Level Continue to Step 3
- STEP 3 Measure the voltage on pin 1 of IC U38 (MC1488)  
 • Result = -12 VDC Level Continue to Step 4

*If any result is incorrect, Refer to Section 1.1 TROUBLESHOOTING THE A500 SYSTEM POWER SUPPLY*

- (P) STEP 4 Measure the signal on pin 41 (RST)\* of IC U5 (GARY)  
 • Result = 0 to +5 VDC shortly after system power up Continue to Step 5
- (P) STEP 5 Measure the signal on pin 11 (RESET)\* of IC U37 (74LS32)  
 • Result = 0 to +5 VDC shortly after system power up Continue to Step 6
- (P) STEP 6 Measure the signal on pin 8 (IORESET)\* of IC U37 (74LS32)  
 • Result = 0 to +5 VDC shortly after system power up Continue to Step 7

*If any result is incorrect, Refer to Section 1.2 TROUBLESHOOTING THE A500 SYSTEM RESET*

- STEP 7 Measure the signal on pin 15 (CLK) of IC U1 (68000)  
 • Result = 7 MHZ Clock Continue to Step 8
- STEP 8 Measure the signal on pin 4 (CCK)\* of IC U33 (74F04)  
 • Result = Approximately 3.58 MHZ Clock Continue to Step 9
- STEP 9 Measure the signal on pin 6 (CCKQ)\* of IC U33 (74F04)  
 • Result = Approximately 3.58 MHZ Clock Continue to Step 10
- STEP 10 Measure the signal on pin 10 (CDAC) of IC U33 (74F04)  
 • Result = Approximately 7 MHZ Clock Continue to Section 2

*If any result is incorrect, Refer to Section 1.3 TROUBLESHOOTING THE A500 SYSTEM CLOCKS*

ALL THE SIGNALS LISTED, STEP 1 THROUGH STEP 10, MUST BE PRESENT  
 FOR THE SYSTEM TO PRODUCE THE CORRECT VIDEO DISPLAY  
 IF ALL SIGNALS SEEM TO BE CORRECT, BEGIN THE STEPS LISTED IN  
 SECTIONS 2 THROUGH 3 — TROUBLESHOOTING THE A500 CONTROL SIGNALS

\*INDICATES ACTIVE LOW

**A500 SYSTEM TROUBLESHOOTING (Continued)**

**SECTION 1.1 — TROUBLESHOOTING THE A500 SYSTEM POWER SUPPLY**

By referring to this section, it is assumed that one or more of the +5 VDC, +12 VDC or -12 VDC measurements from BASIC PRELIMINARY CHECKS, STEPS 1 through 3 are incorrect.

**LINE FILTER (LF1) PINOUTS — FROM FRONT OF PCB**

Pin 4	Pin 3	Pin 2	Pin 1
★	★	★	★
+12V	+12V	-5V	GND
+12V	-12V	VCC	SH/GND
★	★	★	★
Pin 5	Pin 6	Pin 7	Pin 8

**1.1.1 INCORRECT (+5) VDC SUPPLY**

- |   |   |
|---|---|
| <p>STEP 1 Disconnect the disk drive assembly and measure the voltage on pin 1 (right pin) of connector CN12</p> <ul style="list-style-type: none"> <li>• Result = +5 VDC Level</li> <li>• Result = Incorrect</li> </ul> | <p>Defective Drive Assembly<br/>Continue to Step 2</p>                          |
| <p>STEP 2 Measure the voltage on pin 7 (VCC) of line filter (LF1)</p> <ul style="list-style-type: none"> <li>• Result = +5 VDC Level</li> <li>• Result = Incorrect</li> </ul>   | <p>No +5 VDC Problem or<br/>Open +5 VDC Trace<br/>Continue to Step 3</p>        |
| <p>STEP 3 Measure the voltage on pin 2 (+5) of line filter (LF1)</p> <ul style="list-style-type: none"> <li>• Result = +5 VDC Level</li> <li>• Result = Incorrect</li> </ul>  | <p>Defective Filter LF1<br/>Defective Power Supply or<br/>Shorted Component</p> |

**1.1.2 INCORRECT (+12) VDC SUPPLY**

- |   |   |
|---|---|
| <p>STEP 4 Disconnect the disk drive assembly and measure the voltage on pin 4 (left pin) of connector CN12</p> <ul style="list-style-type: none"> <li>• Result = +12 VDC Level</li> <li>• Result = Incorrect</li> </ul> | <p>Defective Drive Assembly<br/>Continue to Step 5</p>                          |
| <p>STEP 5 Measure the voltage on pin 5 (+12V) of line filter (LF1)</p> <ul style="list-style-type: none"> <li>• Result = +12 VDC Level</li> <li>• Result = Incorrect</li> </ul>   | <p>No +12 VDC Problem or<br/>Open +12 VDC Trace<br/>Continue to Step 6</p>      |
| <p>STEP 6 Measure the voltage on pin 4 (+12) of line filter (LF1)</p> <ul style="list-style-type: none"> <li>• Result = +12 VDC Level</li> <li>• Result = Incorrect</li> </ul>  | <p>Defective Filter LF1<br/>Defective Power Supply or<br/>Shorted Component</p> |

**1.1.3 INCORRECT (-12) VDC SUPPLY**

- |   |   |
|---|---|
| <p>STEP 7 Measure the voltage on pin 6 (-12V) of line filter (LF1)</p> <ul style="list-style-type: none"> <li>• Result = -12 VDC Level</li> <li>• Result = Incorrect</li> </ul> | <p>No -12 VDC Problem or<br/>Open -12 VDC Trace<br/>Continue to Step 8</p>      |
| <p>STEP 8 Measure the voltage on pin 3 (-12V) of line filter (LF1)</p> <ul style="list-style-type: none"> <li>• Result = -12 VDC Level</li> <li>• Result = Incorrect</li> </ul> | <p>Defective Filter LF1<br/>Defective Power Supply or<br/>Shorted Component</p> |

**A500 SYSTEM TROUBLESHOOTING (Continued)**

**SECTION 1.2 — TROUBLESHOOTING THE A500 SYSTEM RESET**

By referring to this section, it is assumed that one or more of the reset signals from BASIC PRELIMINARY CHECKS, STEPS 4 through 6 are incorrect.

**1.2.1 INCORRECT (RST) RESET**

- |   |  |
|---|--|
| <p>(P) STEP 1 Measure the signal 5 (KBRESET)* of IC U5 (GARY)</p> <ul style="list-style-type: none"> <li>• Result = 0 VDC to +5 VDC shortly after system power up</li> <li>• Result = Incorrect</li> </ul>              | <p>Continue to Step 2<br/>Continue to Step 1.1</p>   |
| <p>(P) STEP 1.1 Measure the signal on collector of transistor Q711 (2N3904)</p> <ul style="list-style-type: none"> <li>• Result = 0 VDC to +5 VDC Level shortly after power up</li> <li>• Result = Incorrect</li> </ul> | <p>KBRESET OK or Open Reset Trace<br/>Continue to Step 1.2</p>                               |
| <p>(P) STEP 1.2 Measure the signal on pin 3 (OUT) of IC U42 (555)</p> <ul style="list-style-type: none"> <li>• Result = +5 VDC to 0 VDC Level shortly after power up</li> <li>• Result = Incorrect</li> </ul>           | <p>Defective Q711, U5 Keyboard, Connector CN13<br/>Defective U42 or Associated Circuitry</p> |

**1.2.2 INCORRECT (RESET) OR (IORESET) RESET**

- |   |   |
|---|---|
| <p>(P) STEP 2 Measure the signal on pin 12 (RST)* of IC U37 (74LS32)</p> <ul style="list-style-type: none"> <li>• Result = 0 VDC to +5 VDC shortly after power up</li> <li>• Result = Incorrect</li> </ul>          | <p>Continue to Step 3<br/>Defective U5, U1, U2, U37</p>               |
| <p>(P) STEP 3 Measure the signal on pin 11 (RESET)* of IC U37 (74LS32)</p> <ul style="list-style-type: none"> <li>• Result = 0 VDC to +5 VDC shortly after system power up</li> <li>• Result = Incorrect</li> </ul> | <p>RESET OK or Open Reset Trace<br/>Defective U37, U7, U8</p>         |
| <p>(P) STEP 4 Measure the signal on pin 8 (IORESET)* of IC U37 (74LS32)</p> <ul style="list-style-type: none"> <li>• Result = 0 VDC to +5 VDC Level shortly after power up</li> <li>• Result = Incorrect</li> </ul> | <p>IORESET OK or Open Reset Trace<br/>Defective U37 Connector CN7</p> |

**SECTION 1.3 — TROUBLESHOOTING THE A500 SYSTEM CLOCKS**

**1.3.1 INCORRECT (CLK) CLOCK**

- |   |  |
|---|--|
| <p>STEP 1 Measure the signal on pin 34 (28MHZ) of IC U2 (FAT AGNUS)</p> <ul style="list-style-type: none"> <li>• Result = 28 MHZ Clock</li> <li>• Result = Incorrect</li> </ul> | <p>Continue to Step 2<br/>Defective X1, U2</p>       |
| <p>STEP 2 Measure the signal on pin 38 (7MHZ) of IC U2 (FAT AGNUS)</p> <ul style="list-style-type: none"> <li>• Result = 7 MHZ Clock</li> <li>• Result = Incorrect</li> </ul>   | <p>CLK OK or Open Trace<br/>Defective U2, U1, U4</p> |

**1.3.2 INCORRECT (CCK) CLOCK**

- |  |  |
|--|--|
| <p>STEP 3 Measure the signal on pin 28 (CCK) of IC U5 (GARY)</p> <ul style="list-style-type: none"> <li>• Result = 3.58 MHZ Clock</li> <li>• Result = Incorrect</li> </ul> | <p>Defective U33, U4<br/>Defective U5, U2, U3, U4, U33</p> |
|--|--|

**1.3.3 INCORRECT (CCKQ) CLOCK**

- |   |  |
|---|--|
| <p>STEP 4 Measure the signal on pin 27 (CCKQ) of IC U5 (GARY)</p> <ul style="list-style-type: none"> <li>• Result = 3.58 MHZ Clock</li> <li>• Result = Incorrect</li> </ul> | <p>Defective U33<br/>Defective U5, U2, U3, U33</p> |
|---|--|

**1.3.4 INCORRECT (CDAC) CLOCK**

- |   |  |
|---|--|
| <p>STEP 5 Measure the signal on pin 26 (CDAC)* of IC U5 (GARY)</p> <ul style="list-style-type: none"> <li>• Result = 7 MHZ Clock</li> <li>• Result = Incorrect</li> </ul> | <p>Defective U33<br/>Defective U5, U2, U4, U33</p> |
|---|--|

\*INDICATES ACTIVE LOW

**A500 SYSTEM TROUBLESHOOTING (Continued)**

**SECTION 2 — TROUBLESHOOTING THE MOTOROLA 68000 PROCESSOR**

All initial power up signals must be processed by the 68000. In order for the correct power up sequence to take place, the 68000 control signals must be operating correctly.

Although the 68000 will probably initialize with signals of +2.5 VDC levels or above, a problem exists if control signals do not reach close to the +5 VDC levels.

- |  |   |
|--|---|
| <p>STEP 1 Measure the signal on pin 17 (HLT)* of IC U1 (68000)</p> <ul style="list-style-type: none"> <li>• Result = +5 VDC Level</li> <li>• Result = Incorrect</li> </ul>   | <p>Continue to Step 1.1<br/>Defective U1, U5</p>  |
| <p>(P) STEP 2 Measure the signal on pin 18 (RST)* of IC U1 (68000)</p> <ul style="list-style-type: none"> <li>• Result = 0 VDC to +5 VDC shortly after power up</li> <li>• Result = Incorrect</li> </ul>   | <p>Continue to Step 1.2<br/>See Section 1.2 Troubleshooting<br/>the A500 System Reset</p> |
| <p>(P) STEP 3 Measure the signal on pin 7-8 (UDS)*, (LDS)* of IC U1 (68000)</p> <ul style="list-style-type: none"> <li>• Result = +5 VDC Level should start pulsing on initialization</li> <li>• Result = Incorrect pin 7 (UDS)</li> <li>• Result = Incorrect pin 8 (LDS)</li> </ul> | <p>Continue to Step 1.3<br/>Defective U1, U5, U2<br/>Defective U1, U5</p>                 |
| <p>(P) STEP 4 Measure the signal on pin 9 (R/_W)* of IC U1 (68000)</p> <ul style="list-style-type: none"> <li>• Result = +5 VDC Level with Negative Pulsing</li> <li>• Result = Incorrect</li> </ul>   | <p>Continue to Step 1.4<br/>Defective U7, U8, U1, U5, U2</p>                              |
| <p>STEP 5 Measure the signal on pin 6 (AS)* of IC U1 (68000)</p> <ul style="list-style-type: none"> <li>• Result = +5 VDC Sawtooth</li> <li>• Result = Incorrect</li> </ul>  | <p>Continue to Step 1.5<br/>Defective U1, U5, U2</p>                                      |
| <p>STEP 6 Measure the signal on pin 10 (DTACK)* of IC U1 (68000)</p> <ul style="list-style-type: none"> <li>• Result = +5 VDC Square Wave</li> <li>• Result = Incorrect</li> </ul>   | <p>Continue to Step 1.6<br/>Defective U1, U5</p>  |
| <p>STEP 7 Measure the signal on pin 19,21 (VMA)* (VPA)* of IC U1 (68000)</p> <ul style="list-style-type: none"> <li>• Result = +5 VDC Level with Negative Pulse</li> <li>• Result = Incorrect pin 19 (VMA)</li> <li>• Result = Incorrect pin 21 (VPA)</li> </ul>                     | <p>Continue to Step 1.7<br/>Defective U1<br/>Defective U1, U5</p>                         |
| <p>STEP 8 Measure the signal on pin 15 (CLK) of IC U1 (68000)</p> <ul style="list-style-type: none"> <li>• Result = 7 MHZ Clock</li> <li>• Result = Incorrect</li> </ul>   | <p>Continue to Step 1.8<br/>See Section 1.3 Troubleshooting<br/>the A500 System Clock</p> |
| <p>STEP 9 Measure the signal on pin 20 (E) of IC U1 (68000)</p> <ul style="list-style-type: none"> <li>• Result = +5 VDC Square Wave</li> <li>• Result = Incorrect</li> </ul>  | <p>Continue to Step 10<br/>Defective U7, U8, U1</p>                                       |
| <p>(P) STEP 10 Measure the signal on pin 26,28 (FC2), (FC0) of IC U1 (68000)</p> <ul style="list-style-type: none"> <li>• Result = +5 VDC to 0 VDC with positive pulses</li> <li>• Result = Incorrect (Either or Both)</li> </ul>  | <p>Continue to Step 11<br/>Defective U1, RP102</p>  |
| <p>(P) STEP 11 Measure the signal on pin 27 (FC1) of IC U1 (68000)</p> <ul style="list-style-type: none"> <li>• Result = +5 VDC on power up, then to 5 VDC pulsing</li> <li>• Result = Incorrect</li> </ul>  | <p>Continue to Step 12<br/>Defective U1, RP102</p>  |
| <p>STEP 12 Measure the signal on pin 23 (IPL2)* of IC U1 (68000)</p> <ul style="list-style-type: none"> <li>• Result = +5 VDC Level</li> <li>• Result = Incorrect</li> </ul>   | <p>Continue to Step 13<br/>Defective U1, U3, RP102</p>                                    |

\*INDICATES ACTIVE LOW

**A500 SYSTEM TROUBLESHOOTING (Continued)**

**SECTION 2 — TROUBLESHOOTING THE MOTOROLA 68000 PROCESSOR (Continued)**

- STEP 13 Measure the signal on pin 24,25 (IPL1)\*, (IPL0)\* of IC U1 (68000)
- Result = +5 VDC with Negative Pulses Continue to Step 14
  - Result = Incorrect (Either or Both) Defective U1, U3, RP102
- STEP 14 Measure the signals on pins 22 (BEER)\*, 12 (BGACK)\*, 11 (BG)\*, 13 (BA) of IC U1 (68000)
- Result = +5 VDC Level Continue to Section 2.1
  - Result = Incorrect pin 12 (BGACK) Defective U1, U5, RP104
  - Result = Incorrect pins 22, 11, 13 Defective U1, RP104

**SECTION 3 — TROUBLESHOOTING THE A500 SYSTEM 8520 CIA's**

- STEP 1 Measure the signals on pins 23 (CS)\*, 23 (CS)\* of IC U7, U8 (8520)
- Result = +5 VDC Level with Negative Pulsing Continue to Step 2
  - Result = Incorrect (U7 or U8) Continue to Step 1.1
- STEP 1.1 Measure the input to pin 5 (VMA)\* of IC U37 (74LS32)
- Result = +5 VDC Level with Negative Pulsing Continue to Step 1.2
  - Result = Incorrect Defective U1, U37, RP102
- STEP 1.2 Measure the input to pin 4 (A13) of IC U37 (74LS32)
- Result = 5 V Pulsing Address Defective U37, U7
  - Result = Incorrect U1, U2, U6
- STEP 1.3 Measure the input to pin 1 (A12) of IC U37 (74LS32)
- Result = 5 V Pulsing Address Defective U37, U8
  - Result = Incorrect U1, U2, U6
- STEP 2 Measure the input to pin 22 (W)\* of IC U8 (8520)
- Result = 5 V Pulsing - Should Stabilize on Work Bench Prompt display Continue to Step 3
  - Result = Incorrect Defective U8, U7, U1, U5, U2
- STEP 3 Measure the signal on pin 25 (E) of IC U7 and U8 (8520)
- Result = 5 V Pulsing Continue to Step 4
  - Result = Incorrect Defective U7, U8, U1
- STEP 4 Measure the signal on pin 21 (INT)\* of IC U7 (8520)
- Result = +5 VDC Level - Negative Pulses during disk load Continue to Step 5
  - Result = Incorrect Defective U8, U3
- STEP 5 Measure the signal on pin 21 (INT)\* of IC U8 (8520)
- Result = +5 VDC Level Continue to Step 6
  - Result = Incorrect Defective U7, U3
- STEP 6 Measure the signal on pin 19 (TICK)\* of IC U7 (8520)
- Result = Standard Vertical Sync Continue to Step 7
  - Result = Incorrect Defective U2, U7
- STEP 7 Measure the signal on pin 19 (TICK)\* of IC U8 (8520)
- Result = Standard Horizontal Sync Continue to Step 8
  - Result = Incorrect Defective U2, U8

\*INDICATES ACTIVE LOW

**A500 SYSTEM TROUBLESHOOTING (Continued)**

**SECTION 4 — TROUBLESHOOTING THE A500 SYSTEM VIDEO**

If all listed signals seem to be correct, the processor should be up and the system should be able to produce video information.

To make troubleshooting of the system video easier, both Analog RGB and Digital RGBI, as well as Composite Mode should be checked for proper operation.

**IMPORTANT: USE A KNOWN GOOD MONITOR AND CABLE**

**SECTION 4.1 — INCORRECT OR NO DIGITAL VIDEO DISPLAYED**

- STEP 1** Measure the digital outputs (B0-B7) of IC U40, (B0-B3) of IC U41 (74HCT245)
- Result = Buffered RGBI Video Defective RP402, CN9
  - Result = Incorrect Continue to Step 2
- STEP 2** Measure the digital inputs (A0-A7) of IC U40, (A0-A3) of IC U41 (74HCT245)
- Result = Digital RGB Video Defective U40, U41, HY1
  - Result = Incorrect Defective U4, U40, U41

**SECTION 4.2 — INCORRECT OR NO ANALOG RGB VIDEO DISPLAYED**

- STEP 1** Measure the Analog Outputs (AR, AG, AB) of IC HY1 (VIDEO HYBRID)
- Result = Analog RGB Video Defective EMI 431-433, CN9
  - Result = Incorrect Continue to Step 2
- STEP 2** Measure the Digital Outputs (B0-B7) of IC U40, (B0-B3) of IC U41 (74HCT245)
- Result = Buffered RGBI Video Defective HY1
  - Result = Incorrect Continue to Step 3
- STEP 3** Measure the Digital Inputs (A0-A7) of IC U40, (A0-A3) of IC U41 (74HCT245)
- Result = Digital RGB Video Defective U40, U41
  - Result = Incorrect (U40) Defective U4, U40, U41

**SECTION 4.3 — INCORRECT OR NO COMPOSITE VIDEO DISPLAY**

- STEP 1** Measure the Composite Output (Comp) of IC HY1 (VIDEO HYBRID)
- Result = Composite Video and Sync Defective EMI 435, CN10
  - Result = Incorrect (Video) Continue to Step 2
  - Result = Incorrect (Sync) Continue to Section 3.6
- STEP 2** Measure the Digital Outputs (B0-B7) of IC U40, (B0-B3) of IC U41 (74HCT245)
- Result = Buffered RGBI Video Defective HY1
  - Result = Incorrect Continue to Step 3
- STEP 3** Measure the Digital Inputs (A0-A7) of IC U40, (A0-A3) of IC U41
- Result = Digital RGBI Video Defective U40, U41
  - Result = Incorrect Defective U4, U40, U41

**SECTION 4.4 — INCORRECT OR NO RGB VERTICAL SYNC**

- STEP 1** Measure the signal on pin 5 of RP403 (RESISTOR PACK)
- Result = Standard Vertical Sync Defective RP403, CN9
  - Result = Incorrect Defective U2, RP403

**SECTION 4.5 — INCORRECT OR NO RGB HORIZONTAL SYNC**

- STEP 1** Measure the signal on pin 3 of RP403 (RESISTOR PACK)
- Result = Standard Horizontal Sync Defective RP403, CN9
  - Result = Incorrect Defective U2, RP403

**A500 SYSTEM TROUBLESHOOTING (Continued)**

**SECTION 4.6 — INCORRECT OR NO COMPOSITE SYNC**

- |   |  |
|---|--|
| <p>STEP 1 Measure the signal on the output (B7) of IC U41 (74HCT245)</p> <ul style="list-style-type: none"> <li>• Result = Standard Composite Sync</li> <li>• Result = Incorrect</li> </ul> | <p>Defective HY1<br/>Continue to Step 2</p>    |
| <p>STEP 2 Measure the signal on the input (A7) of IC U41 (74HCT245)</p> <ul style="list-style-type: none"> <li>• Result = Standard Composite Sync</li> <li>• Result = Incorrect</li> </ul>  | <p>Defective U41<br/>Defective U2, U4, U41</p> |

**SECTION 5 — TROUBLESHOOTING THE A500 SYSTEM INTERNAL DRIVE CIRCUITS**

If video information is being displayed, but errors are encountered while trying to read from or write to the Internal Drive, the control signals to this circuitry should be checked for proper operation.

**IMPORTANT: USE A KNOWN GOOD DRIVE ASSEMBLY TO ELIMINATE THE DRIVE ITSELF AS THE POSSIBLE CAUSE OF ERRORS**

**SECTION 5.1 — DRIVE MOTOR DOES NOT OPERATE CORRECTLY**

- |  |  |
|--|--|
| <p>STEP 1 Measure the signal on pin 7 (MTR)*, 16 (SEL)* of IC U5 (GARY)</p> <ul style="list-style-type: none"> <li>• Result = High to Low Toggle = Motor On</li> <li style="padding-left: 20px;">Stays High = Motor Off</li> <li>• Result = Incorrect</li> </ul> | <p>Continue to Step 2<br/><br/>Defective U8, U5</p>          |
| <p>STEP 2 Measure the signal on pin 46 (MTRON) of IC U5 (GARY)</p> <ul style="list-style-type: none"> <li>• Result = High = Motor On</li> <li style="padding-left: 20px;">Low = Motor Off</li> <li>• Result = Incorrect</li> </ul>                               | <p>Continue to Step 3<br/><br/>Defective U5, U36</p>         |
| <p>STEP 3 Measure the signal on pin 6 (MTR0)* of IC U36 (74LS38)</p> <ul style="list-style-type: none"> <li>• Result = Low = Motor On</li> <li style="padding-left: 20px;">High = Motor Off</li> <li>• Result = Incorrect</li> </ul>                             | <p>Continue to Step 4<br/><br/>Defective U36, Q503, CN11</p> |
| <p>STEP 4 Measure the signal on pin 12 (SIDE)* of IC U8 (8520)</p> <ul style="list-style-type: none"> <li>• Result = High to Low Toggle = Motor On</li> <li style="padding-left: 20px;">Stays High = Motor Off</li> <li>• Result = Incorrect</li> </ul>          | <p>Continue to Step 5<br/><br/>Defective U8, CN11</p>        |
| <p>STEP 5 Measure the signal on pin 10 (STEP)* of IC U8 (8520)</p> <ul style="list-style-type: none"> <li>• Result = High Level with Negative Pulsing during motor on and head step time</li> <li>• Result = Incorrect (U40)</li> </ul>                          | <p>Continue to Step 6<br/><br/>Defective U8, CN11</p>        |
| <p>STEP 6 Measure the signal on pin 24 (INDEX)* of IC U8 (8520)</p> <ul style="list-style-type: none"> <li>• Result = High Level with Wide Negative Index Pulses</li> <li>• Result = Incorrect</li> </ul>  | <p>Continue to Step 7<br/>Defective U8, CN11</p>             |
| <p>STEP 7 Measure the signal on pin 7 (RDY)* of IC U7 (8520)</p> <ul style="list-style-type: none"> <li>• Result = High to Low Toggle = Motor On</li> <li style="padding-left: 20px;">High Level = Motor Off</li> <li>• Result = Incorrect</li> </ul>            | <p>Continue to Step 8<br/><br/>Defective U7, CN11</p>        |
| <p>STEP 8 Measure the signal on pin 6 (TRK0)* of IC U7 (8520)</p> <ul style="list-style-type: none"> <li>• Result = High to Low Toggle each time disk is inserted</li> <li>• Result = Incorrect</li> </ul>   | <p>Continue to Step 9<br/>Defective U7, CN11</p>             |

\* INDICATES ACTIVE LOW

**A500 SYSTEM TROUBLESHOOTING (Continued)**

**SECTION 5.1 — TROUBLESHOOTING THE A500 SYSTEM INTERNAL DRIVE CIRCUITS (Continued)**

- |  |  |
|--|--|
| <p><b>STEP 9</b> Measure the signal on pin 5 (WPROT)* of IC U7 (8520)</p> <ul style="list-style-type: none"> <li>• Result = Write-Protect OFF (Tab Closed - High Level)<br/>Write-Protect ON (Tab Open - High or Low Toggle) each time disk is inserted</li> <li>• Result = Incorrect</li> </ul> | <p>Continue to Step 10</p> <p>Defective U7, CN11</p>       |
| <p><b>STEP 10</b> Measure the signal on pin 4 (CHNG)* of IC U7 (8520)</p> <ul style="list-style-type: none"> <li>• Result = High Level with Negative Pulsing each time disk is removed from drive</li> <li>• Result = Incorrect</li> </ul>   | <p>Continue to Step 11</p> <p>Defective U7, CN11</p>       |
| <p><b>STEP 11</b> Measure the signal on pin 3 (LED)* of IC U7 (8520)</p> <ul style="list-style-type: none"> <li>• Result = +5 VDC to 0 VDC Level when Power LED comes on</li> <li>• Result = Incorrect</li> </ul>  | <p>Replace Socketed ICs</p> <p>Defective U7, Q502, U33</p> |
| <p><b>STEP 12</b> Measure the signal on pin 37 (DKRD)* of IC U3 (PAULA)</p> <ul style="list-style-type: none"> <li>• Result = +5 VDC Level with Negative Pulsing during disk read</li> <li>• Result = Incorrect</li> </ul>   | <p>Continue to Step 13</p> <p>Defective U3, CN11</p>       |

**ERROR DURING DISK WRITE**

- |  |   |
|--|---|
| <p><b>STEP 13</b> Measure the signal on pin 8 (DKWDB)* of IC U36 (74LS38)</p> <ul style="list-style-type: none"> <li>• Result = +5 VDC Level with Negative Pulsing</li> <li>• Result = Incorrect</li> </ul>    | <p>Continue to Step 14</p> <p>Continue to Step 13.1</p> |
| <p><b>STEP 13.1</b> Measure the signal on pin 45 (DKWDB) of IC U5 (GARY)</p> <ul style="list-style-type: none"> <li>• Result = 0 VDC Level with Positive Pulsing</li> <li>• Result = Incorrect</li> </ul>      | <p>Defective U36</p> <p>Continue to Step 13.2</p>       |
| <p><b>STEP 13.2</b> Measure the signal on pin 38 (DKWD)* of IC U3 (PAULA)</p> <ul style="list-style-type: none"> <li>• Result = +5 VDC Level with Negative Pulsing</li> <li>• Result = Incorrect</li> </ul>    | <p>Defective U5</p> <p>Defective U3, U5</p>             |
| <p><b>STEP 14</b> Measure the signal on pin 11 (DKWEB)* of IC U36 (74LS38)</p> <ul style="list-style-type: none"> <li>• Result = High to Low Toggle during disk write</li> <li>• Result = Incorrect</li> </ul> | <p>Continue to Step 15</p> <p>Continue to Step 14.1</p> |
| <p><b>STEP 14.1</b> Measure the signal on pin 44 (DKWEB) of IC U5 (GARY)</p> <ul style="list-style-type: none"> <li>• Result = Low to High Toggle during disk write</li> <li>• Result = Incorrect</li> </ul>   | <p>Defective U36, CN9</p> <p>Continue to Step 14.2</p>  |
| <p><b>STEP 14.2</b> Measure the signal on pin 39 (DKWE) of IC U3 (PAULA)</p> <ul style="list-style-type: none"> <li>• Result = Low to High Toggle during disk write</li> <li>• Result = Incorrect</li> </ul>   | <p>Defective U5</p> <p>Defective U3, U5</p>             |

\*INDICATES ACTIVE LOW

**A500 SYSTEM TROUBLESHOOTING (Continued)**

**SECTION 6 — TROUBLESHOOTING THE A500 SYSTEM CONTROL PORTS**

If the system reaches normal power up and errors are encountered while trying to access the icons or erratic mouse or joystick operation is encountered, the control port circuitry should be checked for proper operation.

Use a standard joystick for testing these ports.

**IMPORTANT: USE A KNOWN GOOD MOUSE OR JOYSTICK TO ELIMINATE THIS AS THE POSSIBLE CAUSE OF ERRORS**

**CONTROL PORT 0 ERROR — CN1**

- |  |   |
|--|---|
| <p><b>STEP 1</b> Measure the input on pin 2 (1A) of IC U15 (72LS157)</p> <ul style="list-style-type: none"> <li>• Result = +5 VDC to 0 VDC = UP</li> <li>• Result = Incorrect</li> </ul>                                       | <p>Continue to Step 2<br/>Defective U15, EMI411, RP401, CN1</p> |
| <p><b>STEP 2</b> Measure the input on pin 3 (1B) of IC U15 (74LS157)</p> <ul style="list-style-type: none"> <li>• Result = +5 VDC to 0 VDC = LEFT</li> <li>• Result = Incorrect</li> </ul>                                     | <p>Continue to Step 3<br/>Defective U15, EMI412, RP401, CN1</p> |
| <p><b>STEP 3</b> Measure the input on pin 5 (2A) of IC U15 (74LS157)</p> <ul style="list-style-type: none"> <li>• Result = +5 VDC to 0 VDC = DOWN</li> <li>• Result = Incorrect</li> </ul>                                     | <p>Continue to Step 4<br/>Defective U15, EMI413, RP401, CN1</p> |
| <p><b>STEP 4</b> Measure the input on pin 6 (2B) of IC U15 (74LS157)</p> <ul style="list-style-type: none"> <li>• Result = +5 VDC to 0 VDC = RIGHT</li> <li>• Result = Incorrect</li> </ul>                                    | <p>Continue to Step 5<br/>Defective U15, EMI414, RP401, CN1</p> |
| <p><b>STEP 5</b> Measure the output on pin 2 (FIRE0) on EMI415</p> <ul style="list-style-type: none"> <li>• Result = +5 VDC to 0 VDC = FIRE</li> <li>• Result = Incorrect</li> </ul>   | <p>Continue to Step 6<br/>Defective EMI415, U7, CN1</p>         |
| <p><b>STEP 6</b> Measure the output on pin 4 (1Y) of IC U15 (74LS157)</p> <ul style="list-style-type: none"> <li>• Result = +5 VDC Level = CENTER<br/>Multiplexed Output = UP/LEFT</li> <li>• Result = Incorrect</li> </ul>    | <p>Continue to Step 7<br/>Defective U15, U4, RP404, RP405</p>   |
| <p><b>STEP 7</b> Measure the output on pin 7 (2Y) of IC U15 (74LS157)</p> <ul style="list-style-type: none"> <li>• Result = +5 VDC Level = CENTER<br/>Multiplexed Output = RIGHT/DOWN</li> <li>• Result = Incorrect</li> </ul> | <p>Control Port 0 OK<br/>Defective U15, U4, RP404, RP405</p>    |

**CONTROL PORT 1 ERROR — CN2**

- |   |   |
|---|---|
| <p><b>STEP 1</b> Measure the input on pin 11 (3A) of IC U15 (74LS157)</p> <ul style="list-style-type: none"> <li>• Result = +5 VDC to 0 VDC = UP</li> <li>• Result = Incorrect</li> </ul>         | <p>Continue to Step 2<br/>Defective U15, EMI421, RP401, CN2</p> |
| <p><b>STEP 2</b> Measure the input on pin 10 (3B) of IC U15 (74LS157)</p> <ul style="list-style-type: none"> <li>• Result = +5 VDC Level to 0 VDC = LEFT</li> <li>• Result = Incorrect</li> </ul> | <p>Continue to Step 3<br/>Defective U15, EMI422, RP401, CN2</p> |
| <p><b>STEP 3</b> Measure the input on pin 14 (4A) of IC U15 (74LS157)</p> <ul style="list-style-type: none"> <li>• Result = +5 VDC to 0 VDC = DOWN</li> <li>• Result = Incorrect</li> </ul>       | <p>Continue to Step 4<br/>Defective U15, EMI423, RP401, CN2</p> |
| <p><b>STEP 4</b> Measure the input on pin 13 (4B) of IC U15 (74LS157)</p> <ul style="list-style-type: none"> <li>• Result = +5 VDC to 0 VDC = RIGHT</li> <li>• Result = Incorrect</li> </ul>      | <p>Continue to Step 5<br/>Defective U15, EMI424, RP401, CN2</p> |

**A500 SYSTEM TROUBLESHOOTING (Continued)**

**SECTION 6 — TROUBLESHOOTING THE A500 SYSTEM CONTROL PORTS (Continued)**

- |   |   |
|---|---|
| <p><b>STEP 5</b> Measure the output on pin 2 (FIRE1) of EMI425</p> <ul style="list-style-type: none"> <li>• Result = +5 VDC to 0 VDC = FIRE</li> <li>• Result = Incorrect</li> </ul>  | <p>Continue to Step 6<br/>Defective EMI425, U7, CN2</p>       |
| <p><b>STEP 6</b> Measure the output on pin 9 (3Y) of IC U15 (74LS157)</p> <ul style="list-style-type: none"> <li>• Result = +5 VDC Level = CENTER<br/>Multiplexed Output = UP/LEFT</li> <li>• Result = Incorrect</li> </ul>     | <p>Continue to Step 7<br/>Defective U15, U4, RP404, RP405</p> |
| <p><b>STEP 7</b> Measure the output on pin 12 (4Y) of IC U15 (74LS157)</p> <ul style="list-style-type: none"> <li>• Result = +5 VDC Level = CENTER<br/>Multiplexed Output = RIGHT/DOWN</li> <li>• Result = Incorrect</li> </ul> | <p>Control Port 1 OK<br/>Defective U15, U4, RP404, RP405</p>  |

**SECTION 7 — TROUBLESHOOTING THE A500 SYSTEM KEYBOARD CIRCUITS**

If the LED located on the Shift/Lock key goes into a flash code on power up, a failure in the keyboard circuitry is normally indicated. The circuitry located on the physical keyboard is normally at fault when this condition is encountered.

**FLASH CODE FAILURE CHART**

- 1 FLASH = ROM (Internal to the Keyboard Processor)
- 2 FLASHES = RAM (Internal to the Keyboard Processor)
- 3 FLASHES = WATCHDOG TIMER (IC 74LS123 or Associated Circuitry)

If no flashes are displayed or the keyboard is not the cause of the problem, troubleshooting of the main PCB keyboard circuitry will be necessary.

**KEYBOARD CONNECTOR (CN13) PINOUTS — FROM FRONT OF PCB**

Pin 1	Pin 2	Pin 3	Pin 4	Pin 5	Pin 6	Pin 7	Pin 8
★	★	★	★	★	★	★	★
KBDATA	CLOCK	RESET	+5V	KEY	GROUND	STATUS	INUSE

- |  |   |
|--|---|
| <p><b>STEP 1</b> Measure the signal on pins 2 (KBDATA)*, 1 (KBCLOCK)* of Connector CN13</p> <ul style="list-style-type: none"> <li>• Result = +5 VDC Level - Negative Pulsing when key is depressed</li> <li>• Result = Incorrect</li> </ul> | <p>Continue to Step 2<br/>Defective U7, RP501, CN13</p>                   |
| <p><b>STEP 2</b> Measure the signal on pin 3 (KBRESET)* of Connector CN13</p> <ul style="list-style-type: none"> <li>• Result = 0 VDC to +5 VDC shortly after system power up</li> <li>• Result = Incorrect</li> </ul>                       | <p>Continue to Step 3<br/>Refer to Section 1.2 — A500 System Reset</p>    |
| <p><b>STEP 3</b> Measure the signal on pin 7 (STATUS) of Connector CN13</p> <ul style="list-style-type: none"> <li>• Result = 0 VDC to +5 VDC when Power LED comes on</li> <li>• Result = Incorrect</li> </ul>                               | <p>Continue to Step 4<br/>Continue to Step 3.1</p>                        |
| <p><b>STEP 3.1</b> Measure the signal on pin 3 (LED)* of IC U7 (8520)</p> <ul style="list-style-type: none"> <li>• Result = +5 VDC to 0 VDC when Power LED comes on</li> <li>• Result = Incorrect</li> </ul>                                 | <p>Defective Q502 or Associated Circuitry<br/>Defective U7, Q502, U38</p> |
| <p><b>STEP 4</b> Measure the signal on pin 8 (INUSE) of Connector CN13</p> <ul style="list-style-type: none"> <li>• Result = 0 VDC Level - Toggles High each time disk inserted</li> <li>• Result = Incorrect</li> </ul>                     | <p>Keyboard OK<br/>Continue to Step 4.1</p>                               |
| <p><b>STEP 4.1</b> Measure the signal on pin 6 (MTR0)* of IC U36 (74LS38)</p> <ul style="list-style-type: none"> <li>• Result = Low = Motor On<br/>High = Motor Off</li> <li>• Result = Incorrect</li> </ul>                                 | <p>Defective Q503 or Associated Circuitry<br/>Defective U36, Q503</p>     |

\*INDICATES ACTIVE LOW

**A500 SYSTEM TROUBLESHOOTING (Continued)**

**SECTION 8 — TROUBLESHOOTING THE A500 SYSTEM AUDIO CIRCUITS**

In order to determine failures in the audio circuitry it is necessary to generate some type of audio output while checking signals. Selecting the Music Icon from the Extras Disk will work to accomplish this.

If both channels are failing it is recommended that a Dual Trace Scope be used for audio troubleshooting. If only one channel is failing, using a single trace of the scope should be sufficient.

**INCORRECT LEFT AUDIO CHANNEL**

- |        |  |   |
|--------|--|---|
| STEP 1 | Measure the signal on pin 31 (LEFT) of IC U3 (PAULA) |   |
|        | • Result = Approximately 100 mV Audio                | Continue to Step 2                            |
|        | • Result = Incorrect                                 | Defective U3, U14, EMI306                     |
| STEP 2 | Measure the input to pin 13 (–) of IC U14 (LF347)    |   |
|        | • Result = Approximately 100 mV Audio                | Continue to Step 3                            |
|        | • Result = Incorrect                                 | Defective EMI306, U14 or Associated Circuitry |
| STEP 3 | Measure the output on pin 14 of IC U14               |   |
|        | • Result = Approximately 1-2 V Audio                 | Continue to Step 4                            |
|        | • Result = Incorrect                                 | Defective U14 or Associated Circuitry         |
| STEP 4 | Measure the input to pin 3 (+) of IC U14             |   |
|        | • Result = Approximately 1-2 V Audio                 | Continue to Step 5                            |
|        | • Result = Incorrect                                 | Defective R322, R323                          |
| STEP 5 | Measure the output on pin 1 of IC U14                |   |
|        | • Result = Approximately 1-2 V Audio                 | Continue to Step 6                            |
|        | • Result = Incorrect                                 | Defective U14 or Associated Circuitry         |
| STEP 6 | Measure the signal on pin 1 of EMI302                |   |
|        | • Result = Approximately 100 mV Audio                | Continue to Step 7                            |
|        | • Result = Incorrect                                 | Defective C324, C325, R324, R325, EMI302      |
| STEP 7 | Measure the signal on pin 2 (LEFT), of EMI302        |   |
|        | • Result = Approximately 200 mV Audio                | Defective CN4                                 |
|        | • Result = Incorrect                                 | Defective EMI302, CN3                         |

**INCORRECT RIGHT AUDIO CHANNEL**

- |        |   |   |
|--------|---|---|
| STEP 1 | Measure the signal on pin 30 (RIGHT) of IC U3 (PAULA) |   |
|        | • Result = Approximately 100 mV Audio                 | Continue to Step 2                            |
|        | • Result = Incorrect                                  | Defective U3, U14, EMI305                     |
| STEP 2 | Measure the input to pin 9 (–) of IC U14 (LF347)      |   |
|        | • Result = Approximately 100 mV Audio                 | Continue to Step 3                            |
|        | • Result = Incorrect                                  | Defective EMI305, U14 or Associated Circuitry |
| STEP 3 | Measure the output on pin 8 of IC U14 (LF347)         |   |
|        | • Result = Approximately 1-2 V Audio                  | Continue to Step 4                            |
|        | • Result = Incorrect                                  | Defective U14 or Associated Circuitry         |
| STEP 4 | Measure the input to pin 5 (+) of IC U14 (LF347)      |   |
|        | • Result = Approximately 1-2 V Audio                  | Continue to Step 5                            |
|        | • Result = Incorrect                                  | Defective R332, R333                          |
| STEP 5 | Measure the output on pin 7 of IC U14 (LF347)         |   |
|        | • Result = Approximately 1-2 V Audio                  | Continue to Step 6                            |
|        | • Result = Incorrect                                  | Defective U14 or Associated Circuitry         |
| STEP 6 | Measure the signal on pin 1 of EMI303                 |   |
|        | • Result = Approximately 100 mV Audio                 | Continue to Step 7                            |
|        | • Result = Incorrect                                  | Defective C334, C335, R334, R335, EMI303      |
| STEP 7 | Measure the signal on pin 2 (RIGHT) of EMI303         |   |
|        | • Result = Approximately 200 mV Audio                 | Audio OK or Defective CN3                     |
|        | • Result = Incorrect                                  | Defective EMI303, CN3                         |

**A500 SYSTEM TROUBLESHOOTING (Continued)**

**SECTION 9 — TROUBLESHOOTING THE A500 SYSTEM CENTRONICS PORT**

When all control signal to the 8520 CIAs are confirmed good, (See Section 2), the Centronics Parallel Port should be operational. To verify proper operation of this port it is necessary to connect a printer and load software to access it. Signals should be measured as the printer is being accessed.

- |          |  |  |
|----------|--|--|
| STEP 1   | Measure the signals on pin 2 (D0-D7) of EMI512 through EMI519                              |  |
|          | • Result = +5 VDC Level on normal power up will become active when the printer is accessed | Continue to Step 2                     |
|          | • Result = Incorrect   | Continue to Step 1.1                   |
| STEP 1.1 | Measure the signals on pin 1 (PB0-PB7) of EMI512 through EMI519                            |  |
|          | • Result = +5 VDC Level on normal power up will become active when the printer is accessed | Defective EMI512 - EMI519              |
|          | • Result = Incorrect   | Defective U7, EMI512 - EMI519          |
| STEP 2   | Measure the signals on pins 2 (STROBE)*, (ACK)* of EMI511, EMI521                          |  |
|          | • Result = +5 VDC Level on normal power up will become active when the printer is accessed | Continue to Step 3                     |
|          | • Result = Incorrect   | Continue to Step 2.1                   |
| STEP 2.1 | Measure the signals on pins 1 (PC)*, (F)* of EMI511, EMI521                                |  |
|          | • Result = +5 VDC Level on normal power up will become active when the printer is accessed | Defective EMI511, EMI521               |
|          | • Result = Incorrect   | Defective U7, EMI511, EMI521           |
| STEP 3   | Measure the signals on pin 2 (BUSY), (POUT), (SEL) of EMI522 - EMI524                      |  |
|          | • Result = +5 VDC Level on normal power up will become active when the printer is accessed | Continue to Step 4                     |
|          | • Result = Incorrect   | Continue to Step 3.1                   |
| STEP 3.1 | Measure the signals on pin 1 (PA0-PA2) of EMI522 - EMI524                                  |  |
|          | • Result = +5 VDC Level on normal power up will become active when the printer is accessed | Defective EMI522 - EMI524              |
|          | • Result = Incorrect   | Defective U8, EMI522 - EMI524          |
| STEP 4   | All outputs seem correct   | Replace U7, U8 and check Connector CN7 |

**SECTION 10 — TROUBLESHOOTING THE A500 SYSTEM RS232 PORT**

When all control signal to the 8520 CIAs are confirmed good, (See Section 2), the RS232 Serial Port should be operational. To verify proper operation of this port it is necessary to connect a printer and load software to access it. Signals should be measured as the printer is being accessed.

- |          |  |                           |
|----------|--|---------------------------|
| STEP 1   | Measure the signals on pins 2 (TxD), (RTS) of EMI532 through EMI533                        |                           |
|          | • Result = +5 VDC Level on normal power up will become active when the printer is accessed | Continue to Step 2        |
|          | • Result = Incorrect   | Continue to Step 1.1      |
| STEP 1.1 | Measure the signals on pins 4, 9 (PA6), (TxD)* of IC U38 (1488)                            |                           |
|          | • Result = +5 VDC Level on normal power up will become active when the printer is accessed | Defective U38, EMI533,532 |
|          | • Result = Incorrect (PA6)   | Defective U8, U38         |
|          | • Result = Incorrect (TxD)   | Defective U3, U38         |

\*INDICATES ACTIVE LOW

**A500 SYSTEM TROUBLESHOOTING (Continued)****SECTION 10 — TROUBLESHOOTING THE A500 SYSTEM RS232 PORT (Continued)**

- |                 |  |                                    |
|-----------------|--|------------------------------------|
| <b>STEP 2</b>   | Measure the signal on pin 1 (DTR) of EMI531  |                                    |
|                 | • Result = +5 VDC Level on normal power up will become active when the printer is accessed | Continue to Step 3                 |
|                 | • Result = Incorrect   | Continue to Step 2.1               |
| <b>STEP 2.1</b> | Measure the signal on pin 12 (PA7) of IC U38 (1488)  |                                    |
|                 | • Result = +5 VDC Level on normal power up will become active when the printer is accessed | Defective U38, EMI531              |
|                 | • Result = Incorrect   | Defective U8, U38                  |
| <b>STEP 3</b>   | Measure the signals on pins 5-7 (PA3-PA5) of IC U8 (8520)                                  |                                    |
|                 | • Result = +5 VDC Level on normal power up will become active when the printer is accessed | Continue to Step 4                 |
|                 | • Result = Incorrect   | Defective U39, U8, EMI535 - EMI537 |
| <b>STEP 4</b>   | Measure the signal on pins 3 (RxD)* of IC U39 (1489)                                       |                                    |
|                 | • Result = +5 VDC Level on normal power up will become active when the printer is accessed | Continue to Step 5                 |
|                 | • Result = Incorrect   | Defective 39, U3                   |
| <b>STEP 5</b>   | All signals seem correct   | Replace U8, U3, U38, U39           |

\*INDICATES ACTIVE LOW

## **SECTION 4**

### **PARTS**

# SERVICE PARTS REFERENCE DIAGRAM

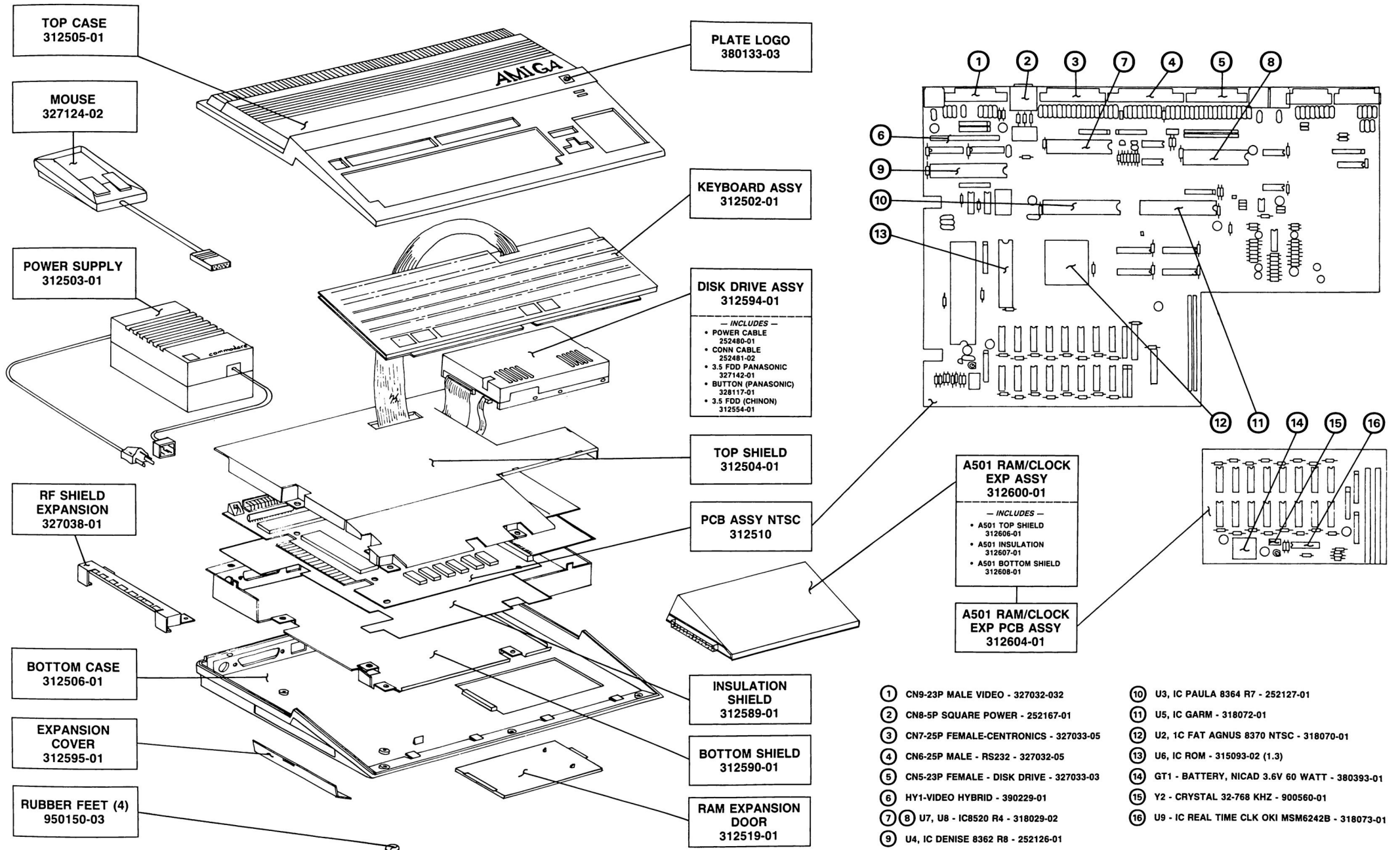

# A500 MAJOR COMPONENT PARTS LIST

Power Cable FDD	C	252480-01
Conn Cable FDD	C	252481-02
Keyboard Assy — USA/Canada	C	312502-01
Power Supply	C	312503-01
Top Shield	C	312504-01
Top Case	C	312505-01
Bottom Case	C	312506-01
PCB Assy — NTSC	C	312510-01
RAM Expansion Door	C	312519-01
Floppy Disk Drive (Chinon)	C	312554-01
Insulation Sheet	C	312589-01
Bottom Shield	C	312590-01
Disk Drive Assy	C	312594-01
Expansion Cover	C	312595-01
A501 RAM/Clock PCB Assy (With Shields)	C	312600-01
A501 RAM/CLK PCB Assy (PCB Only)	C	312604-01
A501 Top Shield		312606-01
A501 Insulation Sheet		312607-01
A501 Bottom Shield		312608-01
Service Manual	C	314981-01
Users Guide, DOS Manual	C	317100-01
Amiga Basic Diskette	C	317488-02
Workbench Diskette	C	317608-01
RF Shield Expansion	C	327038-01
Amiga Basic Manual	C	327102-01
Mouse	C	327124-02
Floppy Disk Drive (Panasonic)	C	327142-01
Button (Panasonic)	C	328117-01
Plate Logo	C	380133-03
Rubber Feet	C	950150-03

**C - Indicates Commodore Stocked Part Number**

## COMPONENT PARTS LIST PCB ASSEMBLY #321510, A500, REV. 5

321510-05 PCB ASSY, A500 NTSC      321510-06 PCB ASSY, A500 PAL

Commodore part numbers are provided for reference only and do not indicate the availability of parts from Commodore. Industry standard parts (Resistors, Capacitors, Connectors) should be secured locally. Approved cross-references for TTL chips, Transistors, etc. are available in manual form through the Service Department, order #314000-01.

IC COMPONENTS			RESISTORS (Continued)		
390084-03	M68000, 8 MHz	U1	901550-22	47K OHM, 5% 1/4W	R712
318070-01	FAT AGNUS, 8370R3 NTSC	U2	901550-84	1M OHM, 5% 1/4W	R711
318071-01	FAT AGNUS, 8371R1, PAL	U2	901550-75	120 OHM, 5% 1/4W	R103-R108
252127-02	PAULA, 8364R7	U3	901550-20	10K OHM, 5% 1/4W	R306,R308
252126-02	DENISE, 8362R8	U4	901550-23	2.7K OHM, 5% 1/4W	R307
318072-01	GARY 5719	U5	901550-82	470K OHM, 5% 1/4W	R326,R336
318029-01	8520R4	U5	901550-89	150 OHM, 5% 1/4W	R409
315093-01	ROM, KICKSTART V1.3	U5	<b>BEADS/FILTERS</b>		
390226-01	256K X 1 BIT DYNAMIC RAM	U16-U31	252133-01	FERRITE BEAD	RB801, RB802
380223-01	256K X 1 BIT DYNAMIC RAM	U16-U31	903025-01	FERRITE BEAD	FB802, FB801,
901882-01	1488	U38			EMI411-EMI417,
901883-01	1489	U39			EMI421-EMI427
390086-01	LF347/TL084	U14	903025-01	FERRITE BEAD	FB802, FB101
390110-01	74F04	U33			EMI411-EMI417,
901521-31	74LS32	U37			EMI421-EMI427,
901521-38	74LS38	U36			EMI402-EMI431-
390081-01	74F74	U32			EMI435
901521-11	74LS157	U15	251842-02	EMI FILTER, 100 pf	EMI301-EMI303,
318050-01	74F244	U34,U35			EMI401-EMI405,
901521-13	74LS244	U10,U12			EMI411-EMI417,
310003-01	74HC245	U40,U41			EMI421-EMI427,
901521-29	74LK373	U11,U13			EMI431-EMI435,
901523-01	NE555	U42			EMI511-EMI538,
252126-01	DENISE, 8362R6	U4			EMI601-EMI611-
380223-05	DRAM, 256K X 1 BIT, 80ns	U16-U31			EMI626, EMI701-
<b>CONNECTORS</b>					EMI704
252167-01	DIN, 5 PIN, SQUARE, FEMALE	CNB	251842-02	EMI FILTER, 100 pf	EMI1101, EMI302,
390242-01	D-SUB, 9 PIN, MALE, RA, SOLDER-IN	CN1, CN2			EMI303, EMI305,
390242-03	D-SUB, 23 PIN, MALE, RA, SOLDER-IN	CN9			EMI306, EMI402-
390241-03	D-SUB/23PIN/FEMALE/RA/SOLDER-IN	CN5			EMI404, EMI407,
390242-05	D-SUB/25PIN/MALE/RA/SOLDER-IN	CN6			EMI431-EMI435,
390241-05	D-SUB/25PIN/FEMALE/RA/SOLDER-IN	CN7			EMI511-EMI524,
252122-04	RCA JACK, BLACK	CN3			EMI531-EMI538,
252122-01	RCA JACK, WHITE	CN4			EMI601, EMI611-
252122-03	RCA JACK, YELLOW	CN10			EMI626, EMI702-
390248-01	RCA JACK, METAL	CN3, CN4, CN10			EMI704
325516-04	HEADER, 4PIN, POLARIZED, SIL	CN12	251842-02	EMI FILTER, 100 pf	EMI1101, EMI302,
903326-08	HEADER, 8PIN, SIL	CN13			EMI303, EMI305,
903345-17	HEADER, 34PIN, DIL	CN11			EMI306, EMI403-
390224-01	HEADER/DUAL/RA/LONG/56POS/MALE	CNX			EMI407, EMI511-
<b>RESISTORS</b>					EMI524, EMI531-
902410-18	NETWORK, 10K X 9 10PIN	RP501			EMI538, EMI601,
390227-03	NETWORK, 22 OHM X 5, 10PIN	RP103			EMI602, EMI611-
902422-05	NETWORK, 47 OHM X 4, 8PIN	RP102, RP403			EMI626, EMI701,
902422-06	NETWORK, 68 OHM X 4, 8PIN	RP210, RP202			EMI702
390227-05	NETWORK, 68 OHM X 5, 10PIN	RP203	<b>CAPACITORS</b>		
902441-10	NETWORK, 120 OHM X 5, 6PIN	RP405	900462-27	39 pF, MLC, AXIAL, NPO	C703
902442-17	NETWORK, 470 OHM X 7, 8PIN	RP104	900462-37	100 pF, MLC, AXIAL, NPO	C704
902410-08	NETWORK, 4.7K X 9, 10PIN	RP101, RP102, RP401,	900463-16	1000 pF MLC AXIAL X7R	C705
		RP501	900463-16	1000 pF MLC AXIAL X7R	C411-C413, C421-C423
902422-06	NETWORK, 68 OHM X 4, 8PIN	RP404	900463-23	3900 pF MLC AXIAL X7R	C323, C333
390186-01	ZERO OHM RESISTOR	W1, W2	900463-26	6800 pF MLC AXIAL X7R	C322, C332
901550-118	1 OHM, 5% 1/4W	EM1301, EM1406	390082-02	.01 uF MLC AXIAL Z5U	C410, C412, C801, C713
901550-129	5.1 OHM, 5% 1/4W	EM1401, R405, R406	390082-02	.01 uF MLC AXIAL Z5U	C308, C713
901550-64	10 OHM, 5% 1/4W	R301, R302	900463-36	.047 uF MLC AXIAL X7R	C311-C314
901550-90	27 OHM, 5% 1/4W	R101, R102	390082-01	.1 uF MLC AXIAL Z5U	C7, C8, C10, C11-C13,
901600-15	47 OHM, 5% 1/2W	EM1501, EM1503			C15, C33-C37, C39,
901550-108	360 OHM, 5% 1/4W	R331, 4321	390082-05	.22 uF MLC AXIAL Z5U	C321, C331, C711,
901550-57	390 OHM, 5% 1/4W	R325, R335			C701(-01 & -02)
901550-58	470 OHM, 5% 1/4W	R305			C1-C6, C16-C32, C14,
901550-01	1K OHM, 5% 1/4W	R303, R304, R324, R334,			C40-C42, C301, C302,
		R713, R305			C305, CS01, CS02
901550-17	1.2K OHM, 5% 1/4W	R704	390082-05	.22 uF MLC AXIAL Z5U	C325, C335
901550-23	2.7K OHM, 5% 1/4W	R701	390101-06	10 uF ELECT RADIAL	C306, C712
901550-39	3.9K OHM, 5% 1/4W	R702	390101-04	22 uF ELECT RADIAL	C303, C304, C307, C334
901550-19	4.7K OHM, 5% 1/4W	R402, R403, R502-R504	390101-01	47 uF ELECT RADIAL	C812-C815, C821, C822
901550-20	10K OHM, 5% 1/4W	R322, R323, R333, R339,	390101-02	100 uF ELECT RADIAL	C307, C811
		R501, R505, R506	900100-56	3300 uF 10 V ELECT RADIAL	C401, C402
901550-15	27K OHM, 5% 1/4W	R703	251029-06	VARIABLE CAP 4.5-45 pf	C702

## COMPONENT PARTS LIST

### PCB ASSEMBLY #321510, A500, REV. 5 (Continued)

TRANSISTORS/DIODES			MISCELLANEOUS (Continued)		
390239-01	TRANS 2N5770 NPN OSC.	Q701	904150-06	SOCKET, 40 PIN DIP	U6-U8
902658-01	TRANS 2N3904 NPN GP	Q501,Q711	251313-01	SOCKET, 48 PIN DIP	U3-U5
902707-01	TRANS 2N3906 PNP GP	Q502,Q503,Q301	251313-02	SOCKET, 48 PIN DIP	U3-U5
390254-01	TRANS JFET PN4302 MPF-102	Q321,Q331	390185-01	SOCKET, 84 PIN PLCC	U2
900850-01	DIODE, 1N4148	D501	904150-10	SOCKET, 64 PIN DIP	U1
CRYSTALS			312519-01	WIRE ASSEMBLY JUMPER	
900556-11	28.63636 MHz	Y1	900462-37	CAP 100 pF MLC AXIAL NOP	C101,R106,R107,R108, R103,EMI402
900556-12	28.37516 MHz	Y1	390082-02	CAP 0.01 uF MLC AXIAL Z5U	C801-C803
325566-14	OSCILLATOR, 28.63636 MHz	X1	380223-03	IC, 256K X 1 BIT DYNAMIC RAM	U16-U31
252344-01	OSCILLATOR, 28.37515 MHz	X1	390226-03	IC, 256K X 1 BIT DYNAMIC RAM	U16-U31
MISCELLANEOUS			390226-05	IC, 256K X 1 BIT DYNAMIC RAM	U16-U31
390229-02	VIDEO HYBRID	HY1	901550-94	RES 68 OHM 5% 1/4W	
390229-01	VIDEO HYBRID	HY1	900463-36	CAP .047 uF MLC AXIAL X7R	
251878-02	LINE FILTER, 8PIN	LF1	320481-01	SHRINK TUBING .50 IN. LG.	
901151-19	CHOKE, 3.3 uH	L701	312511-01	SCHEMATIC	

## COMPONENT PARTS LIST

### PCB ASSEMBLY #312510, AMIGA A500, REV6A/7

312510-07 PCB ASSEMBLY, A500 NTSC      312510-08 PCB ASSEMBLY, A500 PAL

Commodore part numbers are provided for reference only and do not indicate the availability of parts from Commodore. Industry standard parts (Resistors, Capacitors, Connectors) should be secured locally. Approved cross-references for TTL chips, Transistors, etc. are available in manual form through the Service Department, order #314000-01.

IC COMPONENTS			DIODES		
901882-01	INTERFACE MC1488	U38	900850-01	1N4148	D501
901883-03	INTERFACE MC1489	U39	390017-01	1N914	D501
390086-01	LINEAR LF347/TL084	U14	<b>FILTERS</b>		
901523-01	LINEAR NE555	U42	251842-02	EMI FILTER, 100pF	E511-E519,E421-E524, E611-E626
390084-03	MC68000 0MHz	U1	390275-02	EMI FILTER, 150pF	E402,E434,E532,E534
318072-01	MOS 5719 R2 GARY	U5	390297-01	EMI FILTER, 270pF	E305,E306
252126-02	MOS 8362 R8 DENISE	U4	390297-04	EMI FILTER, 470pF	E415-E417,E425-E427, E441-E444,E520,E531, E533,E535-E538
252127-02	MOS 8364 R7 PAULA	U3	390275-01	EMI FILTER, 6800pF	E302,E303,E411-E414, E421-E424
318069-02	MOS 8372 R3 AGNUS HR	U2	390297-05	EMI FILTER .01uF	E101,E401,E403-E408, E601,E602,E702-E704
318029-02	MOS 8520 R4 AMIGA CIA	U7,U8	252173-01	FERRITE BEAD RADIAL	E431-E433,R435
390110-01	TTL 74F04	U33	251878-02	LINE FILTER	LF1
318050-01	TTL 74F244	U34,U35	252133-01	LONG FERRITE BEAD	FB802
310003-01	TTL 74HC245	U40,U41	903025-01	FERRITE BEAD AXIAL	E431-E433,E435
901521-11	TTL 74LS157	U15	<b>TRANSISTORS</b>		
901521-13	TTL 74LS244	U10,U12	390254-01	JFET MPF102/PN4302	Q321,Q331
901521-31	TTL 74LS32	U37	902658-01	NPN 2N3904	Q501,Q711
901521-29	TTL 74LS373	U11,U13	902707-01	PNP 2N3906	Q301,Q502,Q503
901521-38	TTL 74LS38	U36	<b>RESISTORS</b>		
390229-01	VIDEO HYBRID	HY1	901600-36	1/2W CF, 1	R309
318070-01	MOS 8370 R3 FAT AGNUS (NTSC)	U2	901600-50	1/2W CF, 4.7	R401,R405,R406,R408
318071-01	MOS 8371 R1 FAT AGNUS (PAL)	U2	901600-15	1/2W CF, 47	E501-E503
390433-01	MOS 8373 R2 DENISE HR	U4	901550-64	1/4W CF, 10	R301,R302
381099-04	DRAM 256K X 4 120 nS	U16-U19	901550-90	1/4W CF, 27	R101,R102
381099-02	DRAM 256K X 4 100 nS	U16-U19	901550-56	1/4W CF, 47	R103-R107,R113
	NOT LOADED	U20-U23	901550-94	1/4W CF, 68	E104,E105
395093-02	ROM 256K X 16 KICKSTART 1.3	U6	901550-94	1/4W CF, 68	R111,R112,R114
<b>CAPACITORS</b>			901550-94	1/4W CF, 68	XR1
900462-29	MLC AXIAL NOP 47pF	C403	901550-49	1/4W CF, 100	R507
900462-29	MLC AXIAL NOP 47pF	E102,E103,E106-3109	901550-89	1/4W CF, 150	FB101
900462-29	MLC AXIAL NOP 47pF	XC1-XC3	901550-89	1/4W CF, 150	R409
900463-16	MLC AXIAL X7R 1000pF	C411-C413,C421-C423	901550-108	1/4W CF, 360	R321,R331
900463-23	MLC AXIAL X7R 3900pF	C323,C333	901550-57	1/4W CF, 390	R325,R335
900463-26	MLC AXIAL X7R 6800pF	C322,C332	901550-01	1/4W CF, 1K	R303-R305,R324,R334, R713
900463-36	MLC AXIAL X7R .047pF	C311-C314	901550-23	1/4W CF, 2.7K	R307,R502
900463-37	MLC AXIAL X7R .1uF	C321,C331	901550-19	1/4W CF, 4.7K	R201,R202,R402,R403, R503,R504
390082-01	MLC AXIAL Z5U .01uF	C308,C713,C800-C803	901550-20	1/4W CF, 10K	R306,R308,R322,R323, R332,R333,R339,R501, R505,R506
390082-02	MLC AXIAL Z5U .1uF	C711	901550-22	1/4W CF, 47K	R712
390082-04	MLC AXIAL Z5U .33uF	C1-C8,C10-C19,C33- C37,C39-C42,C301, C302,C305,C325,C335, C501,C502,C701,C804 C20-C23	901550-82	1/4W CF, 470K	R326,R336
	NOT LOADED	C306,C712	901550-84	1/4W CF, 1M	R711
390101-06	ELECT ALUM RADIAL, 10uF 16V	C303,C304,C324,C334	902410-11	RES PACK SIP PULLUP, 470 X 9	RP104
390101-04	ELECT ALUM RADIAL, 22uF 35V	C821,C822	902410-08	RES PACK SIP PULLUP, 4.7K X 9	RP101,RP102,RP401
390101-01	ELECT ALUM RADIAL, 47uF 35V	C811-C816	902410-07	RES PACK SIP PULLUP, 10K X 9	RP501
390101-02	ELECT ALUM RADIAL, 100uF 16V	C307	390227-03	RES PACK SIP SERIES, 22 X 5	RP103
390101-03	ELECT ALUM RADIAL 470uF 16V	C401,C402	390227-05	RES PACK SIP SERIES, 68 X 5	RP201,RP203
900100-56	ELECT ALUM RADIAL 3300uF 10V		390227-06	RES PACK SIP SERIES, 47 X 5	RP402,RP403
<b>CONNECTORS</b>			901600-129	RES 1/2W CF, 5.1	R401,R405,R406,R408
325516-04	4PIN FLOPPY POWER	CN12	390227-08	RES PACK SIP SERIES, 39 X 5	RP103
252167-01	5PIN SQ DIN	CN8		NOT LOADED	RP105-RP111,RP405
903335-08	8PIN SIL W/KEY	CN13	<b>MISCELLANEOUS</b>		
390241-03	D-SUB/23PIN/FEMALE/DB23S	CN5	904150-06	SOCKET, 40PIN DIP	U6-U8
390242-03	D-SUB/23PIN/MALE/DB23P	CN9	251313-01	SOCKET, 48PIN DIP	U3-U5
290241-05	D-SUB/25PIN/FEMALE/DE25S	CN7	904150-10	SOCKET, 64PIN DIP	U1
290242-05	D-SUB/25PIN/MALE/DB25P	CN6	390185-01	SOCKET, 84PIN PLCC	U2
390242-01	D-SUB/9PIN/MALE/DB9P	CN1,CN2	251313-02	SOCKET, 48PIN DIP	U3-U5
350903-01	HEADER 34PIN W/KEY	CN11	252344-01	OSCILLATOR, 28.37516MHz (PAL)	X1
390224-07	HEADER 56PIN MALE RA	CN10	325566-14	OSCILLATOR, 28.63636MHz (NTSC)	X1
252122-03	RCA JACK, YELLOW	CN3	312511-03	SCHEMATIC	
252122-01	RCA JACK, WHITE	CN4			
252122-04	RCA JACK, BLACK	CN3			
903326-08	8PIN SIL W/KEY	CN13			
903345-17	HEADER 34PIN W/KEY	CN11			
390248-01	RCA JACK, METAL	CN10			
390248-01	RCA JACK, METAL	CN3,CN4			

## COMPONENT PARTS LIST

### PCB ASSEMBLY RAM EXPANSION/CLOCK

### PCB ASSEMBLY #312604-04, A501, REV. 6C

Commodore part numbers are provided for reference only and do not indicate the availability of parts from Commodore. Industry standard parts (Resistors, Capacitors, Connectors) should be secured locally. Approved cross-references for TTL chips, Transistors, etc. are available in manual form through the Service Department, order #314000-01.

IC COMPONENTS			CONNECTORS		
318099-04	DRAM 256K X 4 120nS	U1-U4	380311-05	HEADER 56PIN FEMALE RA	CNY
318099-02	DRAM 256K X 4 100nS	U1-U4	<b>DIODES</b>		
318073-01	OKI MSM6242B REAL TIME CLOCK	U9	900850-01	SWITCHING 1N4148	D912
390392-01	TTL 74F27 TRIPLE 3-IN NOR	U13	390017-01	SWITCHING 1N914	D911
390198-01	TTL 74F86 QUAD 2-IN XOR	U12	<b>MISCELLANEOUS</b>		
901521-33	TTL 74LS163 BINARY COUNTER	U11	380393-01	BATTERY NICD VARTA 3/60DK, 3.6V 60MAH	BT9
<b>RESISTORS</b>			900560-01	CRYSTAL WATCH STYLE, 32768Hz	Y9
901550-58	1/4W CF, 470	R911,R913	312606-03	FABRICATION DRAWING	
901550-20	1/4W CF, 10K	R912,R914,R915	312578-03	PCB ARTWORK	
390227-05	RES PACK SIP SERIES, 68 X 5 NOT LOADED	RP901-RP903,RP911 RP912	312605-03	SCHEMATIC	
<b>CAPACITORS</b>					
900462-21	MLC AXIAL NPO 22pF	C911			
390082-01	MLC AXIAL Z5U .1uF	C9			
390082-04	MLC AXIAL Z5U .33uF	C1-C4,C11-C13			
251029-06	TRIMMER (YELLOW) 6.8-45pF NOT LOADED	TC9 C10			
390101-02	ELECT ALUM RADIAL 100uF 16V	C902,C903			
900410-13	ELECT TANTALUM RADIAL 4.7uF 16V	C913			
390101-05	ELECT ALUM RADIAL 4.7uF 16V	C913			

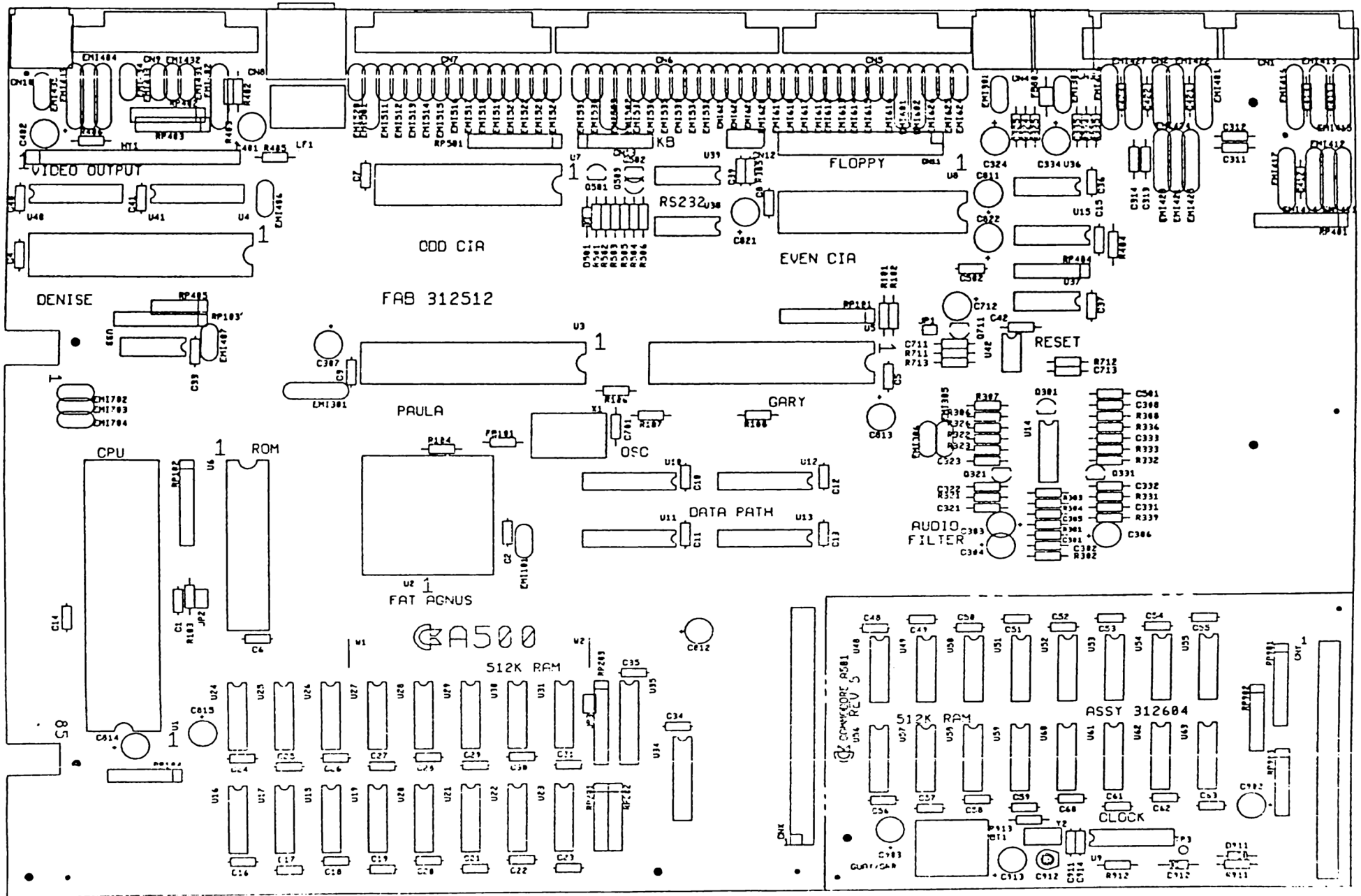

A500 Board Layout #312510, Rev. 5

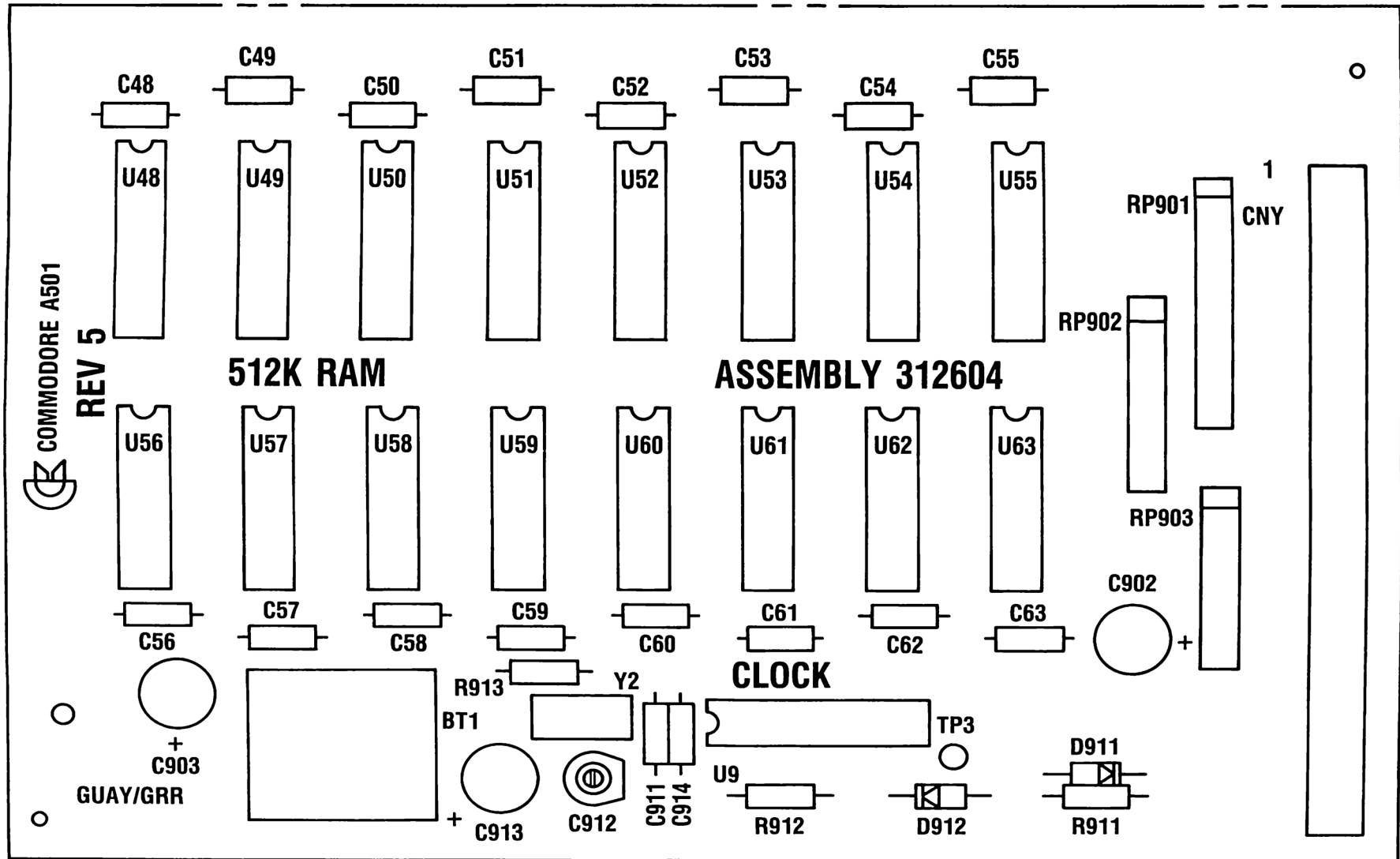

**BOARD LAYOUT**  
**A501 RAM/CLOCK EXPANSION**  
 PCB ASSEMBLY #312604-03

**SECTION 5**  
**SCHEMATICS**

Jumpers and Stuff

REF	TYPE	DESCRIPTION	PAGE
JP1	BLOB	Keyboard Reset	7
JP2	BLOB	Memory Addr. C0 vs 08	2
JP3	BLOB	Int. Memory Res0 vs 1	3
			4
TP1	POST	RTC Frequency Test	9
C912	TRIM	RTC Frequency Adjust	9
W1-2	0 Ohm	Ground Continuity FCC	8

Connectors

REF	TYPE	DESCRIPTION	PAGE
CN1	DB9P	Mouse/Joystick 1	2
CN2	DB9P	Mouse/Joystick 2	2
CN3	RCA-J	Right Audio Output	4
CN4	RCA-J	Left Audio Output	4
CN5	DB25S	External Floppy	7
CN6	DB25P	RS232 Serial Port	6
CN7	DB25S	Parallel Printer Port	6
CN8	SO DIN	Power Supply Connector	8
CN9	DB23P	Video Output	5
CN10	RCA-J	Composite Video	5
CN11	DIL-34	Internal Floppy Signal	7
CN12	SIL-4	Internal Floppy Power	8
CN13	SIL-8	Keyboard Connector	6
P1	EDGE86	Expansion Connector	7
CNX	RA-56H	Mem. Exp. Main-Board	3
CNY	RAS6-F	Mem. Exp. Sub-Board	9

ECO Log

ECO NUMBER	DESCRIPTION	DATE
870152	Additional Parts for FCC	05/12/87
870222	The "Transistor Fix"	06/16/87
870302	Change RI resistor for FTZ	10/09/87
870207	More FCC Changes	09/04/87
880238	Add E Clock Termination	03/03/88

Signal Glossary

SIGNAL	DESCRIPTION (AREA)	PAGES
28MHZ	28.63636 Mhz Master Clock	2
7MHZ	7.15909 Mhz Processor Clock	2,5
A[23:1]	Processor Address Bus (68000)	2,3,7,9
ACK	Data Acknowledge (Parallel Port)	6
AS	Address Strobe (68000)	2,7
AUDIN	Audio Input (RS232 Port)	4,6
AUDOUT	Audio Output (RS232 Jack)	4,6
BFEER	Bus Error (68000)	2,7
BC	Bus Grant (68000)	2,7
BGACK	Bus Grant Acknowledge (68000)	2,7
BLISS	Blitter Slowdown (Chips)	2
BLIT	Chip Memory Access (Chips)	2,7
BR	Bus Request (68000)	2,7
BUSY	Device Busy (Parallel Port)	6
CASL/U	Column Address Strobe (DRAM)	2,3,9
CCK/CCKQ	Color Clock / Quadrature (Chips)	2,4,7
CDAC	7.15909 Mhz Quadrature Clock (Chips)	2,5,7
CHNG	Media Change (Floppy)	6,7
CLKRD/WR	Read-Time Clock Read / Write (RTC)	2,9
COMP	Monochrome Composite Video (Video)	5
CSYNC	Composite Sync (Video)	2,5
CIS	Clear to Send (RS232 Port)	6
D[15:0]	Processor Data Bus (68000)	2,3,6,7,9
DIR	Stop Direction (Floppy)	4,7
DRRD	Disk Read Data (Floppy)	4,7
DRWD	Disk Write Data (Floppy)	4,7
DRXE	Disk Write Enable (Floppy)	4,7
DNAL	Chip DMA Request Line (Chips)	2,4
DRA[8:0]	DRAM Address Bus (DRAM)	2,3,9
DRD[15:0]	DRAM Data Bus (DRAM)	2,3,4,5,9
DSR	Data Set Ready (RS232 Port)	6
DTRACK	Data Transfer Acknowledge (68000)	2,3,7
DTR	Data Terminal Ready (RS232 Port)	6
E	Peripheral Enable Clock (68000)	2,6,7
EXRAM	Expansion Memory Present	2,3,9
FC[2:0]	Function Code (68000)	2,7
FIRE0/1	Fire Button 0/1 (Joysticks)	2,5,6
HIT	Processor Halt (68000)	2,7
HSYNC	Horizontal Sync (Video)	2,5,6
INDEX	Index Pulse (Floppy)	6,7
INT[2,3,6]	Interrupt Request (Chips)	2,4,6,7
I/ORESET	I/O Reset	6,7
IP[2:0]	Interrupt Priority Level (68000)	2,4,7
KBLOCK	Keyboard Clock (Keyboard)	6
KBDATA	Keyboard Data (Keyboard)	6
KBRESET	Keyboard Reset (Keyboard)	6
LDS/WDS	Upper / Lower Data Strobes (68000)	2,7
LED	Power On LED / Audio Filter Disable	4,6

SIGNAL	DESCRIPTION (AREA)	PAGES
LEFT/RIGHT	Left Right Audio (Audio)	4
MTR	Motor On (Floppy)	4,6
MTR0	Motor On - Drive 0 (Floppy)	4,6,7
MOV/MOH	Mouse 0 Quadrature V/H (Joysticks)	5
MIV/MIH	Mouse 1 Quadrature V/H (Joysticks)	5
OVL	Overlay ROM over RAM	2,6
OVR	Override System Decoding	2,7
PIXELSW	Genlock Pixel Switch (Video)	5
POT0X/OY	Pot Lines 0 X/Y (Joysticks)	4,5
POT1X/IY	Pot Lines 1 X/Y (Joysticks)	4,5
POUT	Paper Out (Parallel Port)	6
PPD[7:0]	Parallel Port Data (Parallel Port)	6
RAMEN	RAM Enable (Chips)	2
REGEN	Chip Register Enable (Chips)	2
RAS0/1	Row Address Strobe (DRAM)	2,3,9
RDY	Drive Ready (Floppy)	6,7
RESET	General Reset	6,7
RCA[8:1]	Register Address Bus (Chips)	2,4,5
R/G/B	Red / Green / Blue (Video)	5
RI	Ring Indicate (RS232 Port)	6
ROMEN	ROM Enable (ROM)	2,3
RTS	Request to Send (RS232 Port)	6
RST	Processor Reset (68000)	2,4,7
RXD	Receive Data (RS232 Port)	4,6
RW	Processor Read/Write (68000)	2,6,7
SEL	Select (Parallel Port)	6
SEL[3:0]	Drive Select (Floppy)	4,6,7
SIDE	Side Select (Floppy)	6,7
STEP	Step In/Out Command (Floppy)	6,7
TRKO	Track Zero Sense (Floppy)	6,7
TXD	Transmit Data (RS232 Port)	4,6
VMA	Valid Memory Address (68000)	2,6,7
VPA	Valid Peripheral Address (68000)	2,7
VSXNC	Vertical Sync (Video)	2,5,6
WE	Write Enable (DRAM)	2,3,9
WPROT	Write Protect Sense (Floppy)	6,7
XCLK	External Genlock Clock (Video)	2,5
XCLKEN	External Clock Enable (Video)	2,5
XRDY	External Data Ready	2,5

Key Components

REF	CHIP	DESCRIPTION	PAGE
U1	68000	68000 Processor	2
U2	8370	Fot Agnus - NTSC	2
	8371	Fot Agnus - PAL	olt
	8372	Agnus HR	olt
U3	8364	Paula	4
U4	8362	Denise	5
	8373	Denise HR	olt
U5	5719	Garu	2,4
U6	68st	ROM 128Kx16, 200 nS	3
U7-8	8520	Amiga VIA, 1 Mhz	6
U9	6242B	OKI Bus RTC	9
U14	LF347	81MOS Op-Amp	4
	TL084	81MOS Op-Amp	olt
U38	1488	EIA Line Driver	4
U39	1489	EIA Line Receiver	4
U42	NE555	Timer	7
U16-31	68st	DRAM 256Kx1, 150 nS	3
U48-63	68st	DRAM 256Kx1, 150 nS	9
X1	05C	TTL 28.63636 Mhz NTSC	2
	05C	TTL 28.37512 Mhz PAL	olt
Y2	X1AL	Watch Tape 32768 Hz	9
HY1	68st	Video Hybrid	5

ATTEMPT TO FORCE NODE NUMBERS VIA SEQUENCE

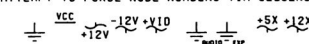

Note: R103-104,106-108,C101 are for EMI Control and may be loaded with funny things...  
JP2 controls where expansion ram maps to:  
A23 -> C00000 (default), A19 -> 080000  
R109/C109,R105 Details, see ECO 880283  
C101 FCC Filter Capacitor per ECO 870207

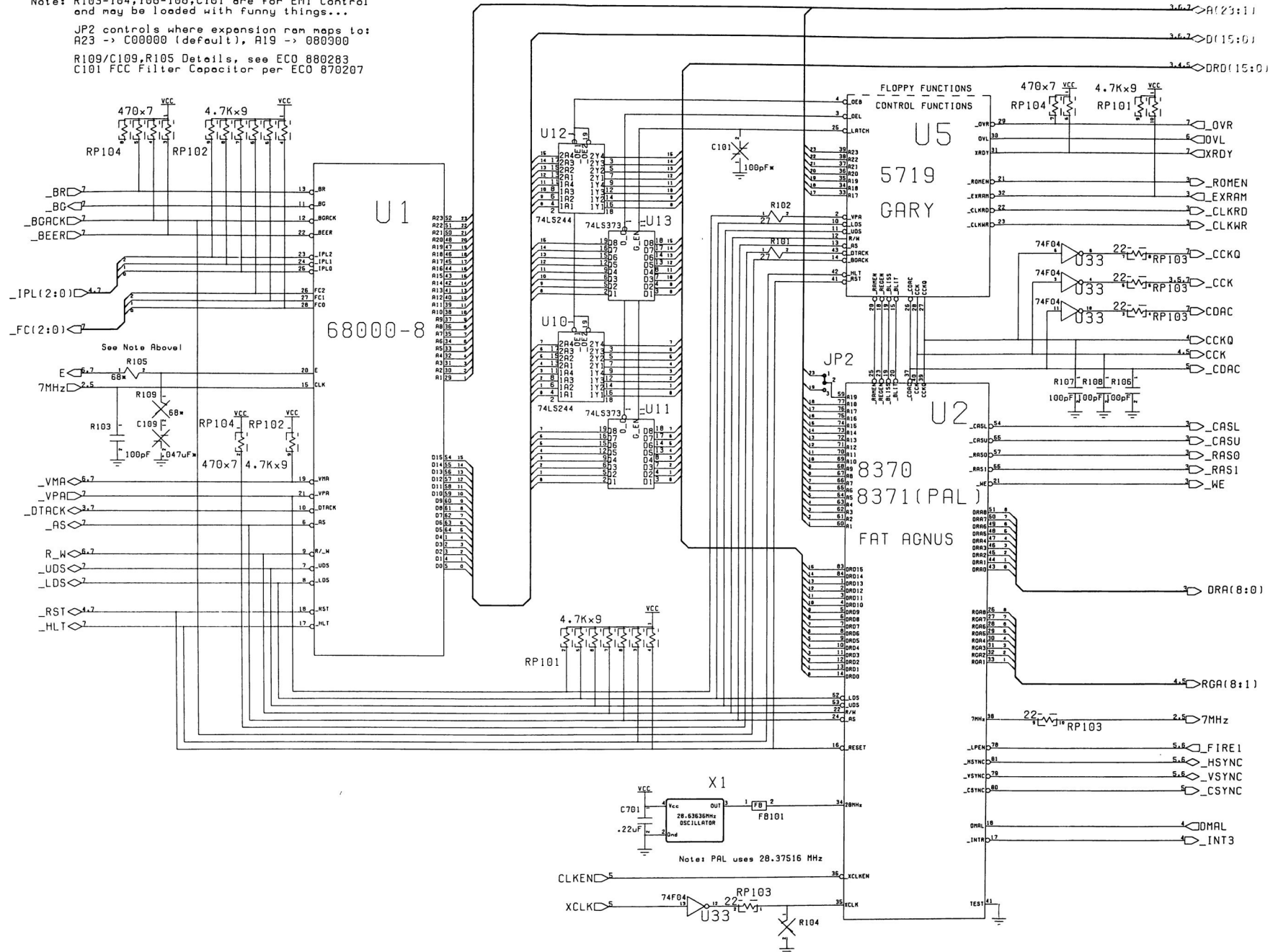

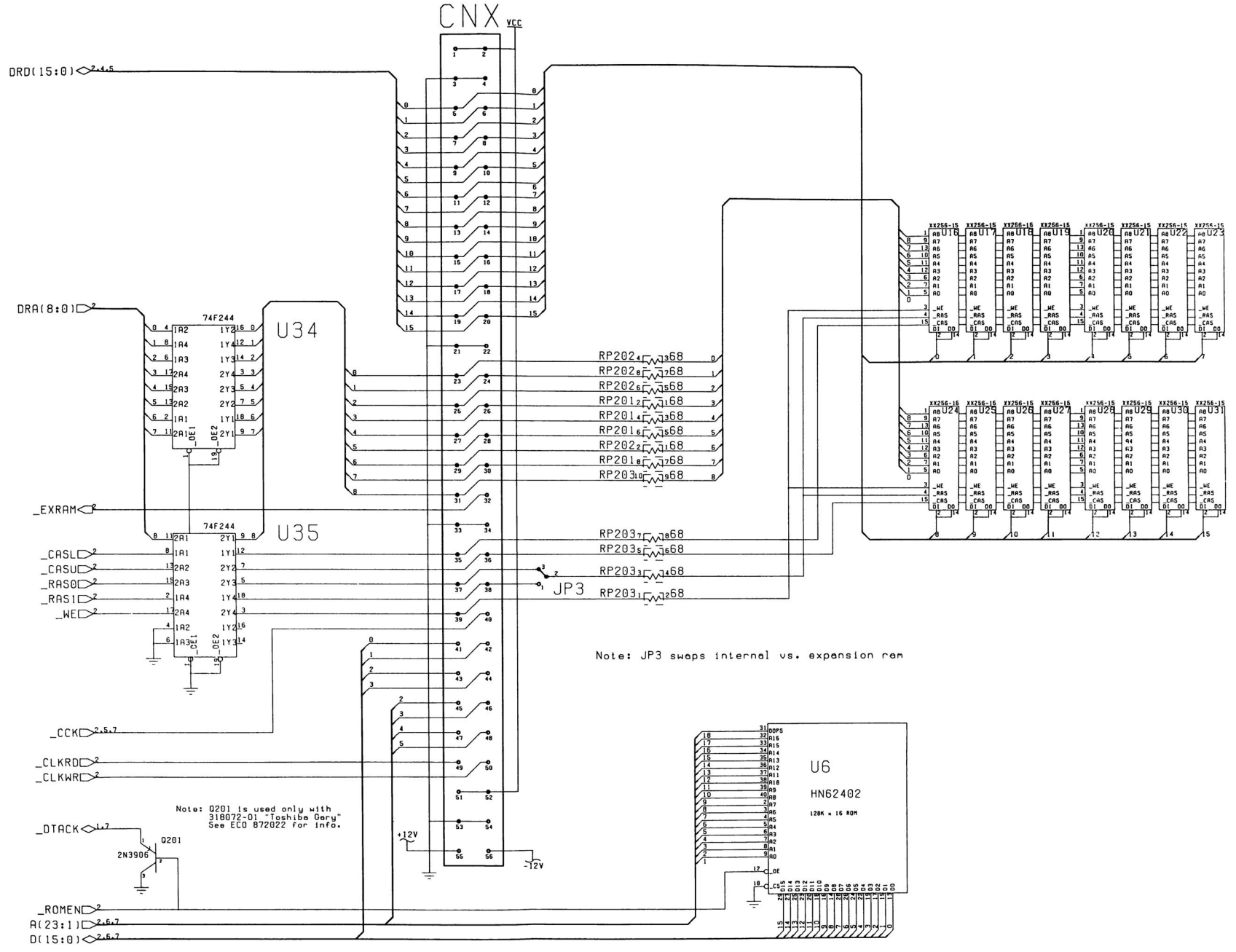

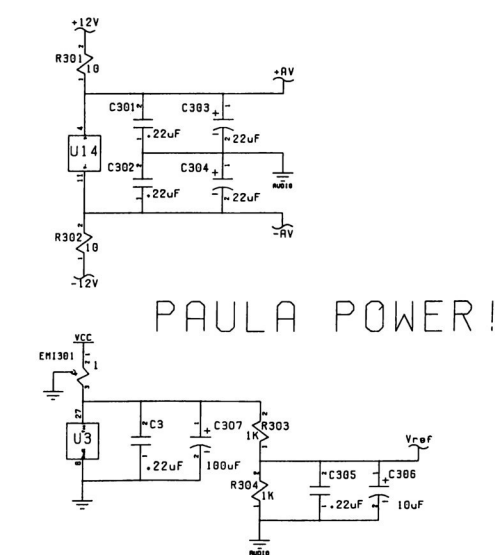
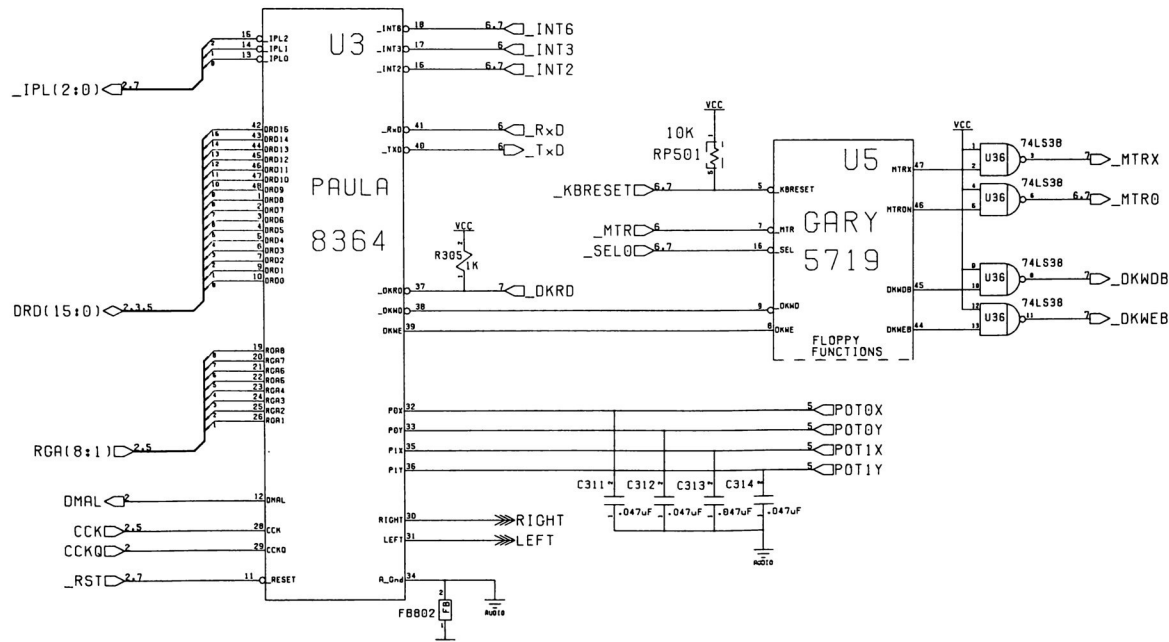
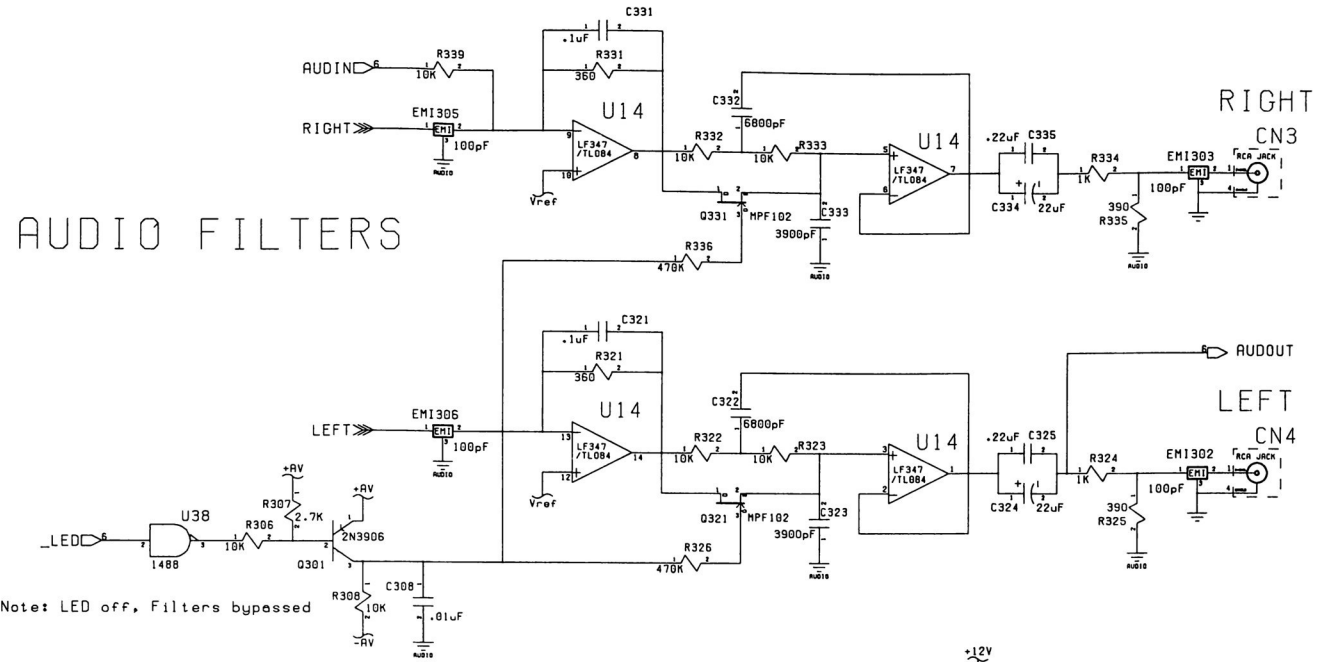

Note: Ground interconnection near audio jacks.

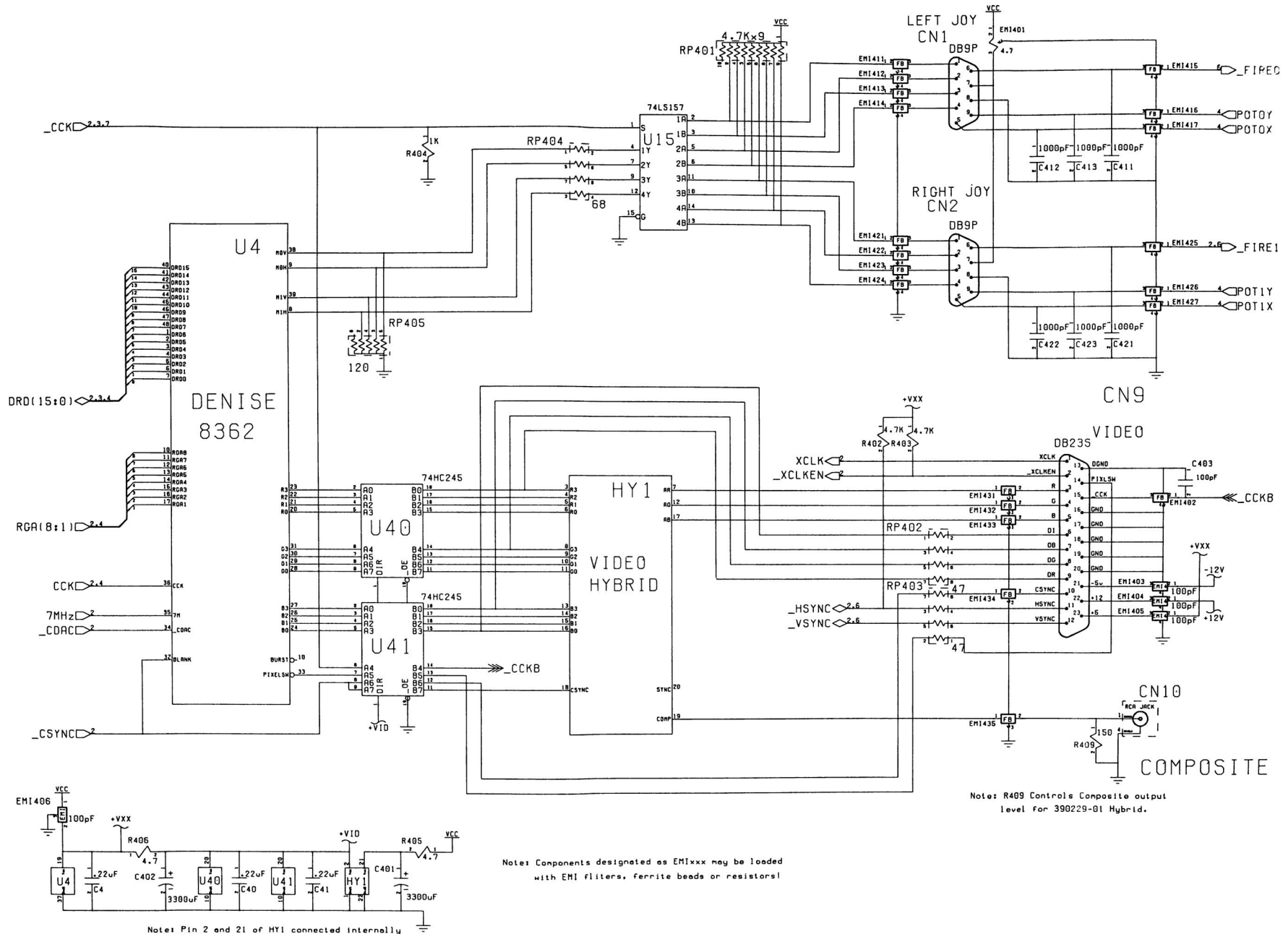

Note: R409 Controls Composite output level for 390229-01 Hybrid.

Note: Components designated as EM1xxx may be loaded with EMI filters, ferrite beads or resistors!

Note: Pin 2 and 21 of HY1 connected internally



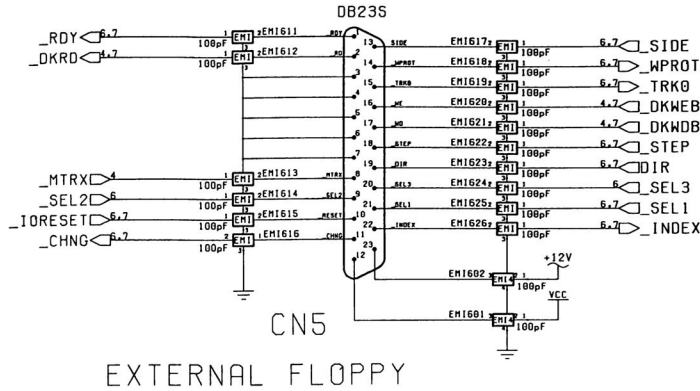

INTERNAL FLOPPY

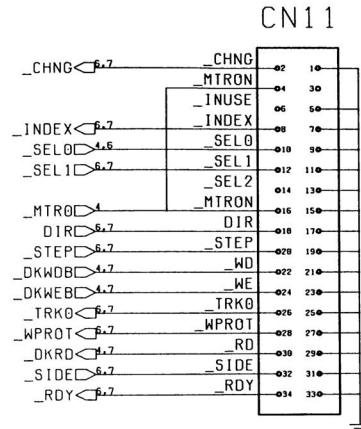

EXPANSION

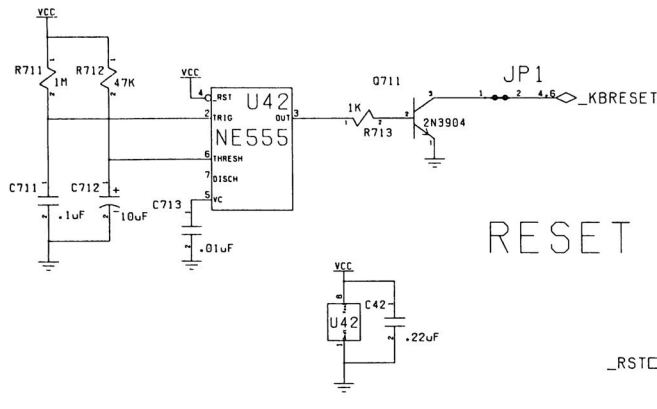
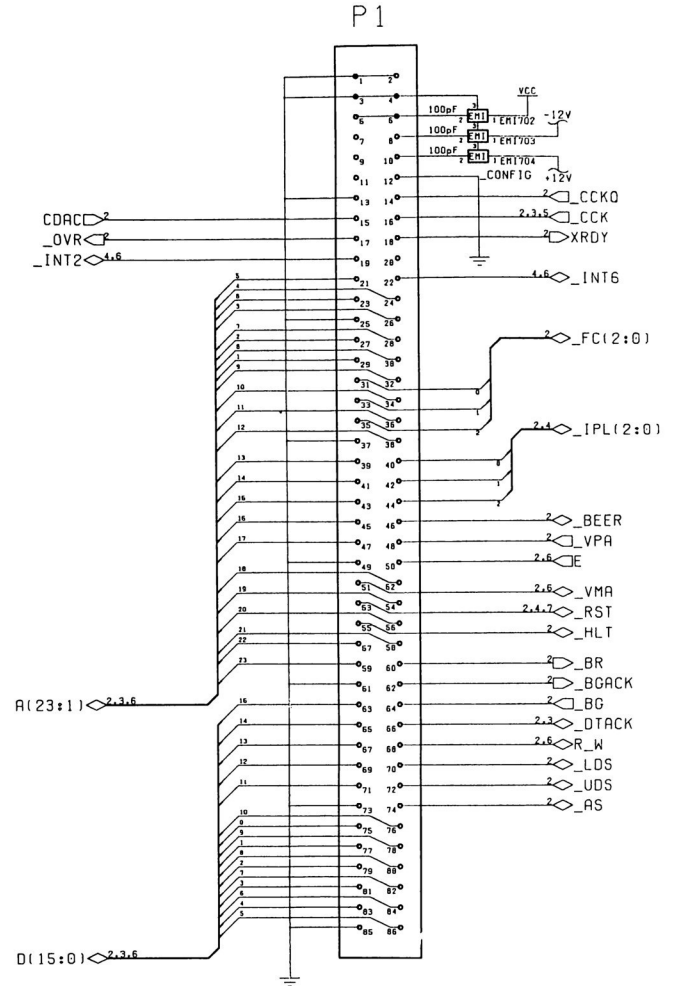

# POWER INPUT

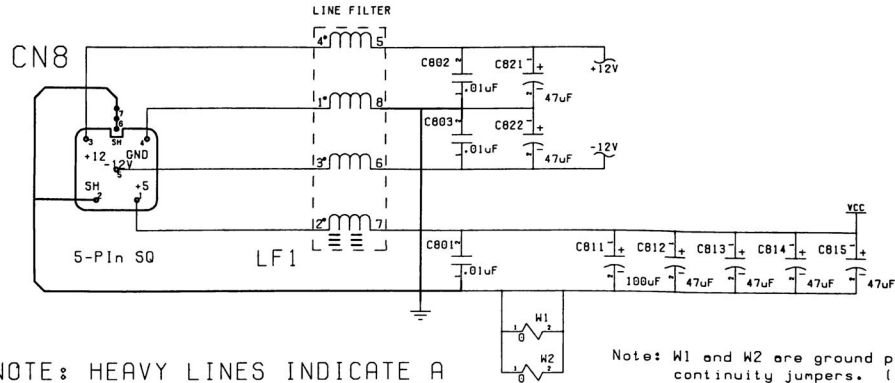

NOTE: HEAVY LINES INDICATE A SINGLE POINT CONNECTION

Note: H1 and H2 are ground plane continuity jumpers. (FCC)

# FLOPPY POWER

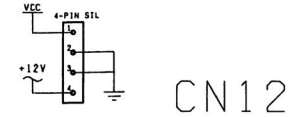

# SPARES

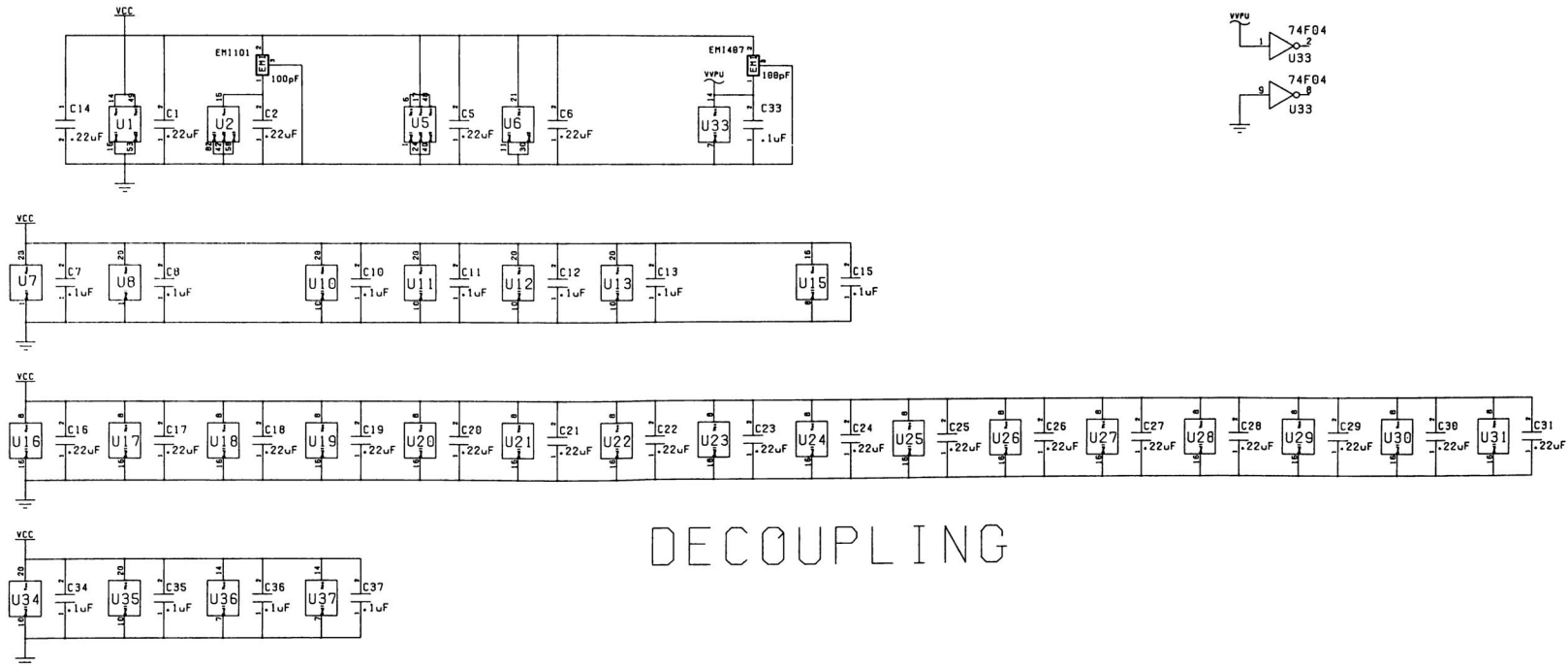
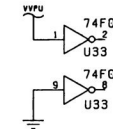

# DECOUPLING



Jumpers and Stuff

REF	TYPE	DESCRIPTION	PAGE
JP1	BLOB	Keyboard Reset	7
JP2	BLOB	Memory Addr. C0 vs 08	2
JP3	BLOB	Expansion RAS Select	3
JP4	BLOB	NTSC/PAL Selection	2
JP5	BLOB	GenLock Clock Select	2
JP6	BLOB	7MHz Clock Option	7
JP7	BLOB	Expansion/Tick Option	3/6
JP8	BLOB	Light Pen Port Select	6
JP10	BLOB	RS232 Audio I/O Cutout	4
JP11	BLOB	TTL vs RS170 Comp Sunde	5

Connectors

REF	TYPE	DESCRIPTION	PAGE
CN1	DB9P	Mouse/Joystick 1	2
CN2	DB9P	Mouse/Joystick 2	2
CN3	RCA-J	Right Audio Output	4
CN4	RCA-J	Left Audio Output	4
CN5	DB25S	External Floppy	7
CN6	DB25P	RS232 Serial Port	6
CN7	DB25S	Parallel Printer Port	6
CN8	50 DIN	Power Supply Connector	8
CN9	DB23P	Video Output	5
CN10	RCA-J	Composite Video	5
CN11	DIL-34	Internal Floppy Signal	7
CN12	SIL-4	Internal Floppy Power	8
CN13	SIL-8	Keyboard Connector	6
P1	EDGE86	Expansion Connector	7
CNX	RA-56H	Men. Exp. Main-Board	3

ECO Log

ECO NUMBER	DESCRIPTION	DATE
880283	Add E Clock Termination	03/03/89

Signal Glossary

SIGNAL	DESCRIPTION (AREA)	PAGES
28MHZ	28.63636 MHz Master Clock	2
7MHZ	7.15909 MHz Processor Clock	2,5
A[23:1]	Processor Address Bus (68000)	2,3,7
ACK	Data Acknowledge (Parallel Port)	6
AS	Address Strobe (68000)	2,7
AUDIN	Audio Input (RS232 Port)	4,6
AUDOUT	Audio Output (RS232 Jack)	4,6
BEFR	Bus Error (68000)	2,7
BC	Bus Grant (68000)	2,7
BCACK	Bus Grant Acknowledge (68000)	2,7
BLISS	Blitter Slowdown (Chips)	2
BLIT	Chip Memory Access (Chips)	2,7
BR	Bus Request (68000)	2,7
BUSY	Device Busy (Parallel Port)	6
CASL/U	Column Address Strobe (DRAM)	2,3
CLK/CLKQ	Color Clock / Quadrature (Chips)	2,4,7
CDAC	7.15909 MHz Quadrature Clock (Chips)	2,5,7
CHNG	Media Change (Floppy)	6,7
CLKRD/WR	Read/Write Clock Read / Write (RTC)	2,9
COMP	Monochrome Composite Video (Video)	5
CSYNC	Composite Sync (Video)	2,5
CIS	Clear to Send (RS232 Port)	6
D[15:0]	Processor Data Bus (68000)	2,3,6,7
DIR	Step Direction (Floppy)	6,7
DKRD	Disk Read Data (Floppy)	4,7
DKWD	Disk Write Data (Floppy)	4,7
DKWF	Disk Write Enable (Floppy)	4,7
DMAL	Chip DMA Request Line (Chips)	2,4
DRAM[8:0]	DRAM Address Bus (DRAM)	2,3
DRAM[15:0]	DRAM Data Bus (DRAM)	2,3,4,5
DSR	Data Set Ready (RS232 Port)	6
DTACK	Data Transfer Acknowledge (68000)	2,3,7
DIR	Data Terminal Ready (RS232 Port)	6
E	Peripheral Enable Clock (68000)	2,6,7
EXTICK	Expansion Present / RTC Tick	2,3
FC[2:0]	Function Code (68000)	2,7
FIRE0/1	Fire Button 0/1 (Joysticks)	2,5,6
HLT	Processor Halt (68000)	2,7
HSYNC	Horizontal Sync (Video)	2,5,6
INDEX	Index Pulse (Floppy)	6,7
INT[2,3,6]	Interrupt Request (Chips)	2,4,6,7
IORSET	I/O Reset	6,7
IP[12:0]	Interrupt Priority Level (68000)	2,4,7
KBCLK	Keyboard Clock (Keyboard)	6
KBDATA	Keyboard Data (Keyboard)	6
KBRESET	Keyboard Reset (Keyboard)	6
LDS/UDS	Upper / Lower Data Strobes (68000)	2,7
LED	Power On LED / Audio Filter Disable	4,6
LEFT/RIGHT	Left Right Audio (Audio)	4

SIGNAL	DESCRIPTION (AREA)	PAGES
LPFN	Light Pen Trigger (Joysticks)	2,6
MTR	Motor On (Floppy)	4,6
MTR0	Motor On - Drive 0 (Floppy)	4,6,7
MOV/M0H	Mouse 0 Quadrature V/H (Joysticks)	5
MIV/M1H	Mouse 1 Quadrature V/H (Joysticks)	5
OVL	Overlay ROM over RAM	2,6
OVR	Override System Decoding	2,7
PIXELSW	GenLock Pixel Switch (Video)	5
P0I0X/OY	Pot Lines 0 X/Y (Joysticks)	4,5
P0I1X/IY	Pot Lines 1 X/Y (Joysticks)	4,5
POUT	Paper Out (Parallel Port)	6
PPD[7:0]	Parallel Port Data (Parallel Port)	6
RAMEN	RAM Enable (Chips)	2
RCEN	Chip Register Enable (Chips)	2
RAS0/1	Row Address Strobe (DRAM)	2,3
RDY	Drive Ready (Floppy)	6,7
RESET	General Reset	6,7
RGA[8:1]	Register Address Bus (Chips)	2,4,5
R/G/B	Red / Green / Blue (Video)	5
RI	Ring Indicate (RS232 Port)	6
ROMEN	ROM Enable (ROM)	2,3
RTS	Request to Send (RS232 Port)	6
RST	Processor Reset (68000)	2,4,7
RXD	Receive Data (RS232 Port)	4,6
RW	Processor Read/Write (68000)	2,6,7
SEL	Select (Parallel Port)	6
SEL[3:0]	Drive Select (Floppy)	4,6,7
SIDE	Side Select (Floppy)	6,7
STEP	Step In/Out Command (Floppy)	6,7
TRK0	Track Zero Sense (Floppy)	6,7
TXD	Transmit Data (RS232 Port)	4,6
VMA	Valid Memory Address (68000)	2,6,7
VPA	Valid Peripheral Address (68000)	2,7
VSYNC	Vertical Sync (Video)	2,5,6
WE	Write Enable (DRAM)	2,3
WPROT	Write Protect Sense (Floppy)	6,7
XCCLK	External GenLock Clock (Video)	2,5
XCLOCKEN	External Clock Enable (Video)	2,5
XRDY	External Data Ready	2,5

Key Components

REF	CHIP	DESCRIPTION	PAGE
U1	68000	68000 Processor	2
U2	8370	Fot Agnus - NTSC	2
	8371	Fot Agnus - PAL	alt
	8372	Agnus HR	alt
U3	8364	Paula	4
U4	8362	Denise	5
	8373	Denise HR	alt
U5	5719	Oryu	2,4
U6	asst	ROM 128Kx16, 200 nS	3
U7-8	8520	Amiga VIA, 1 MHz	6
U14	LF347	BiMOS Op-Amp	4
	TL084	BiMOS Op-Amp	alt
U38	1488	EIA Line Driver	4
U39	1489	EIA Line Receiver	4
U42	NE555	Timer	7
U16-19	asst	DRAM 1Mx1, 150 nS	3
U20-23	asst	DRAM 1Mx1, 150 nS	9
X1	OSC	TTL 28.63636 MHz NTSC	2
	OSC	TTL 28.37512 MHz PAL	alt
HY1	asst	Video Hybrid	5

ATTEMPT TO FORCE NODE NUMBERS VIA SEQUENCE

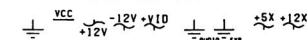

Note: Various components are for EMI Control and may be loaded with funny things...  
 JP2 controls where expansion ram maps to:  
 A23 -> C00000 (default), A19 -> 080000  
 XR1 is added to some boards per ECO 880283

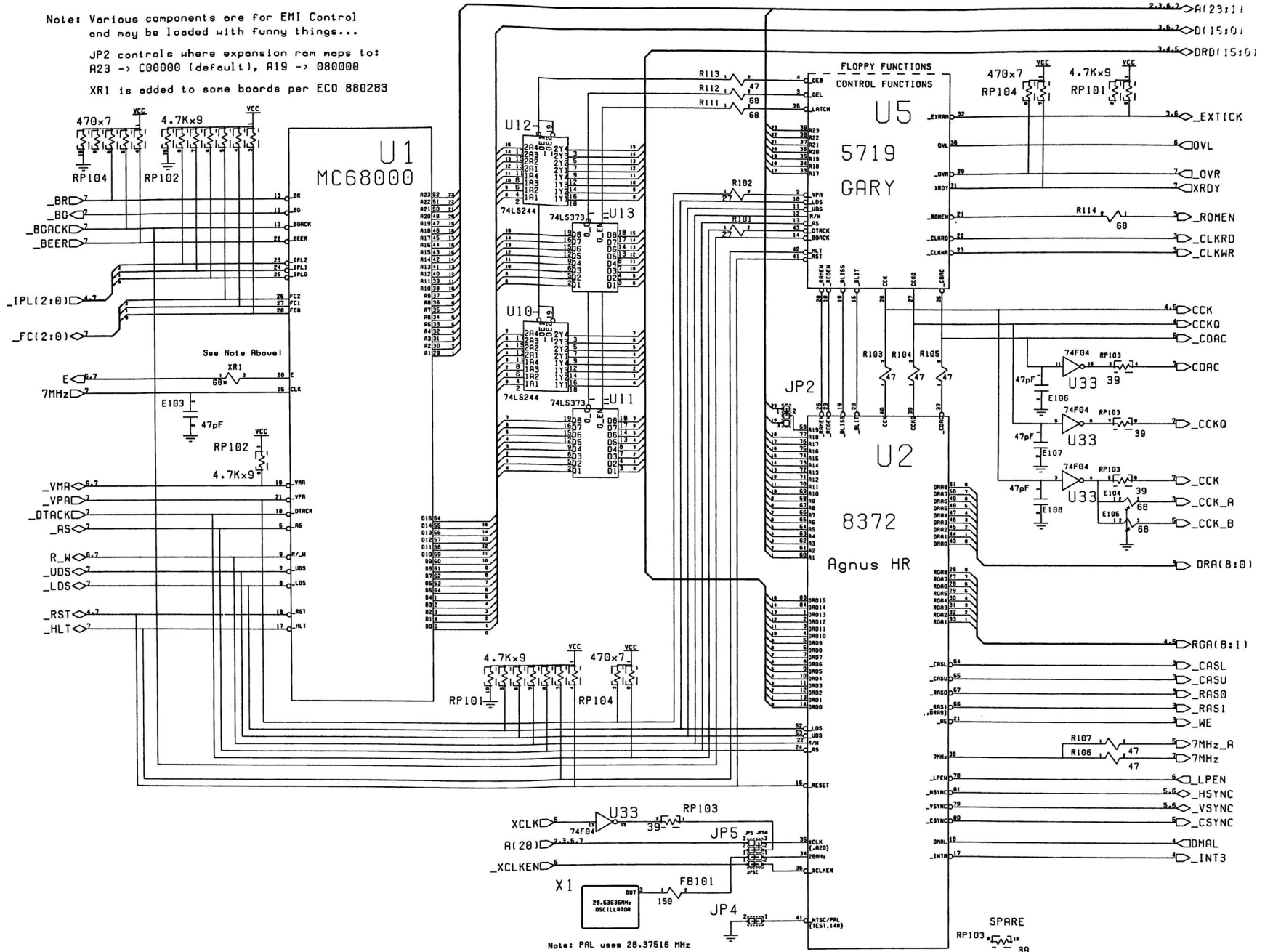

Note: PAL uses 28.37516 MHz

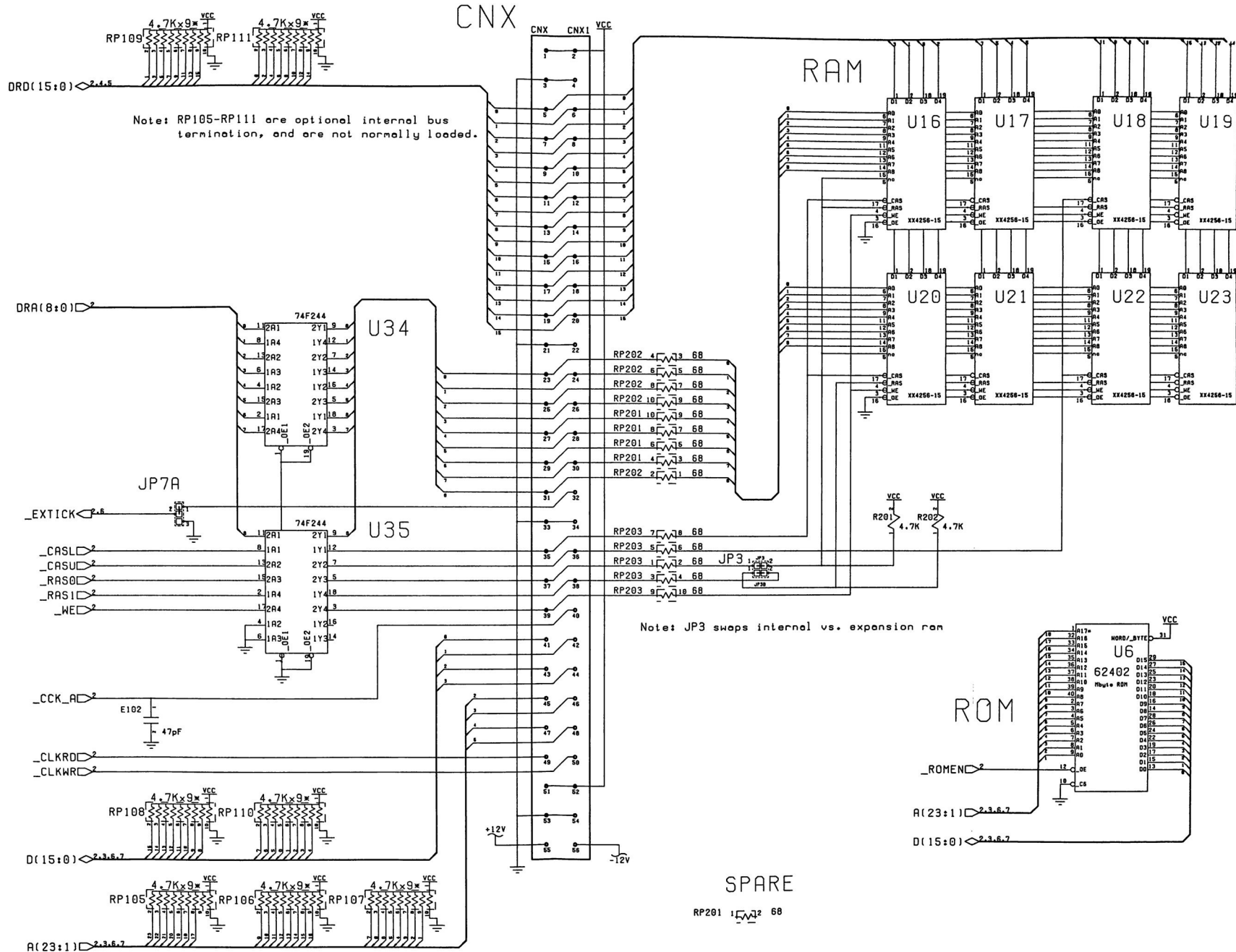

AUDIO FILTERS

Note: LED off, Filters bypassed

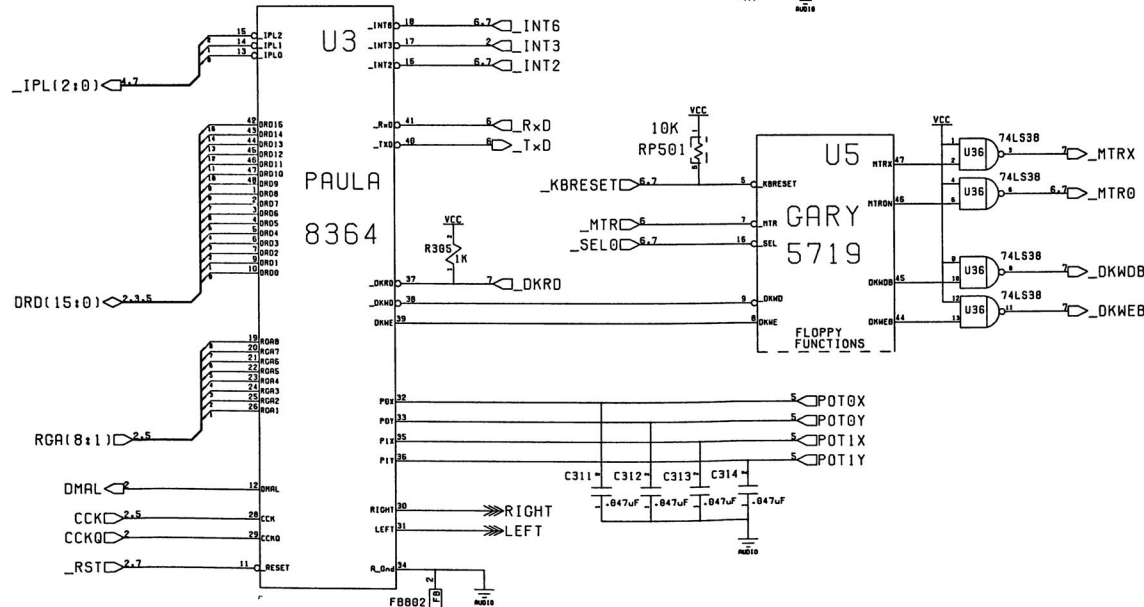
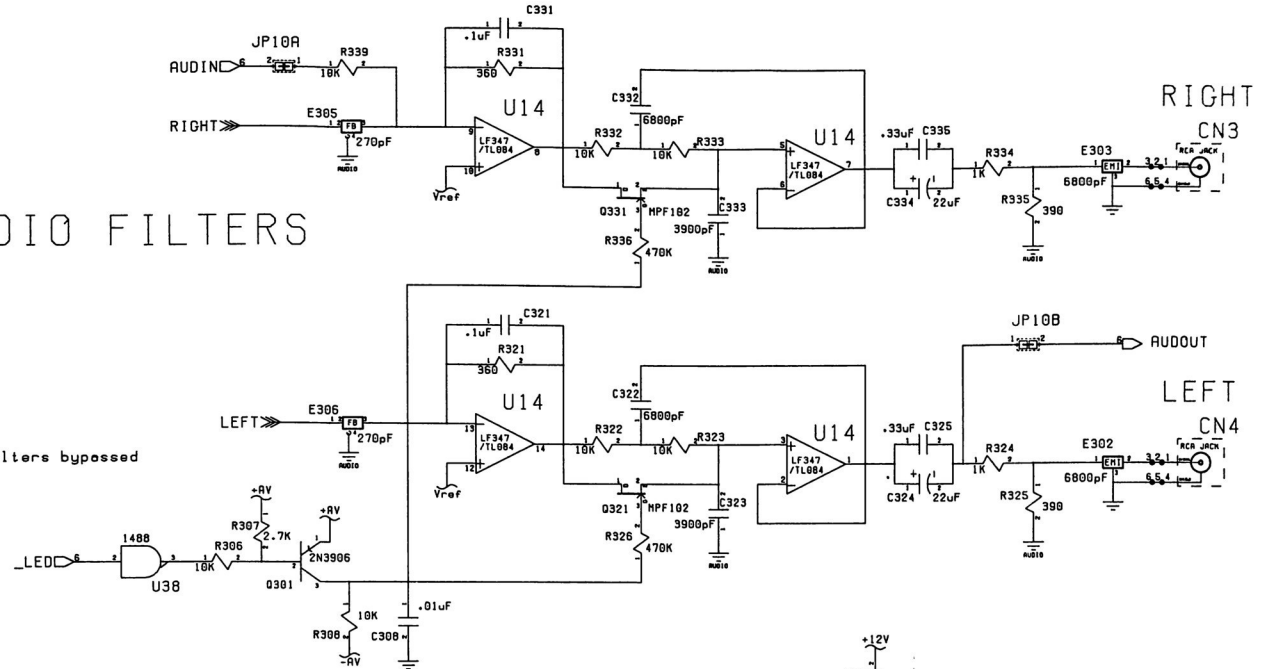

Note: Ground Interconnection near audio Jacks.

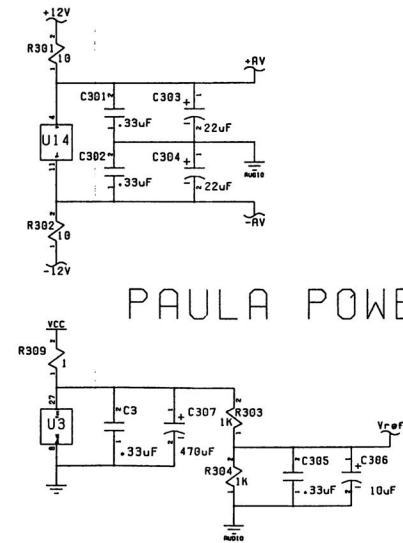

PAULA POWER!

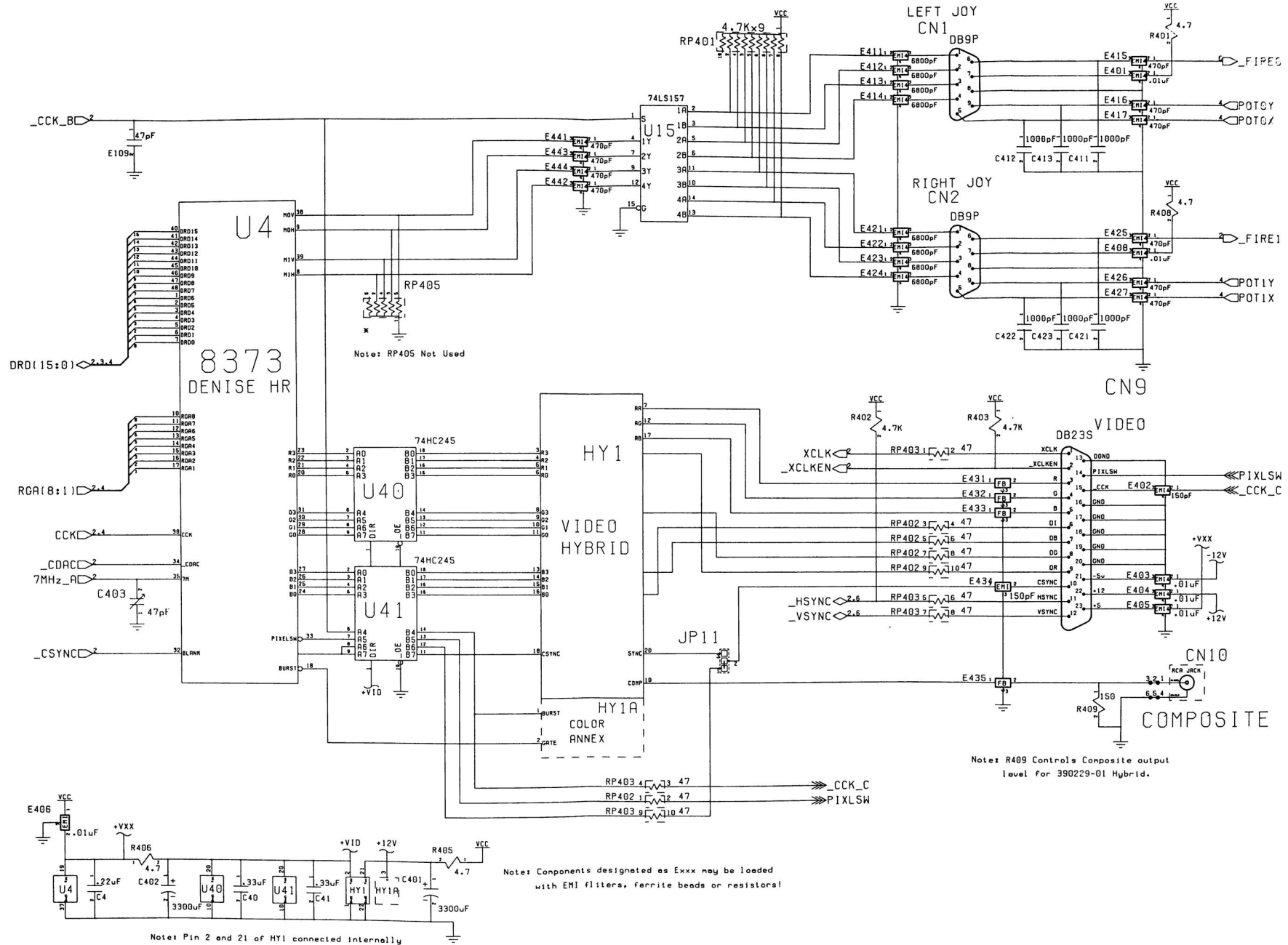

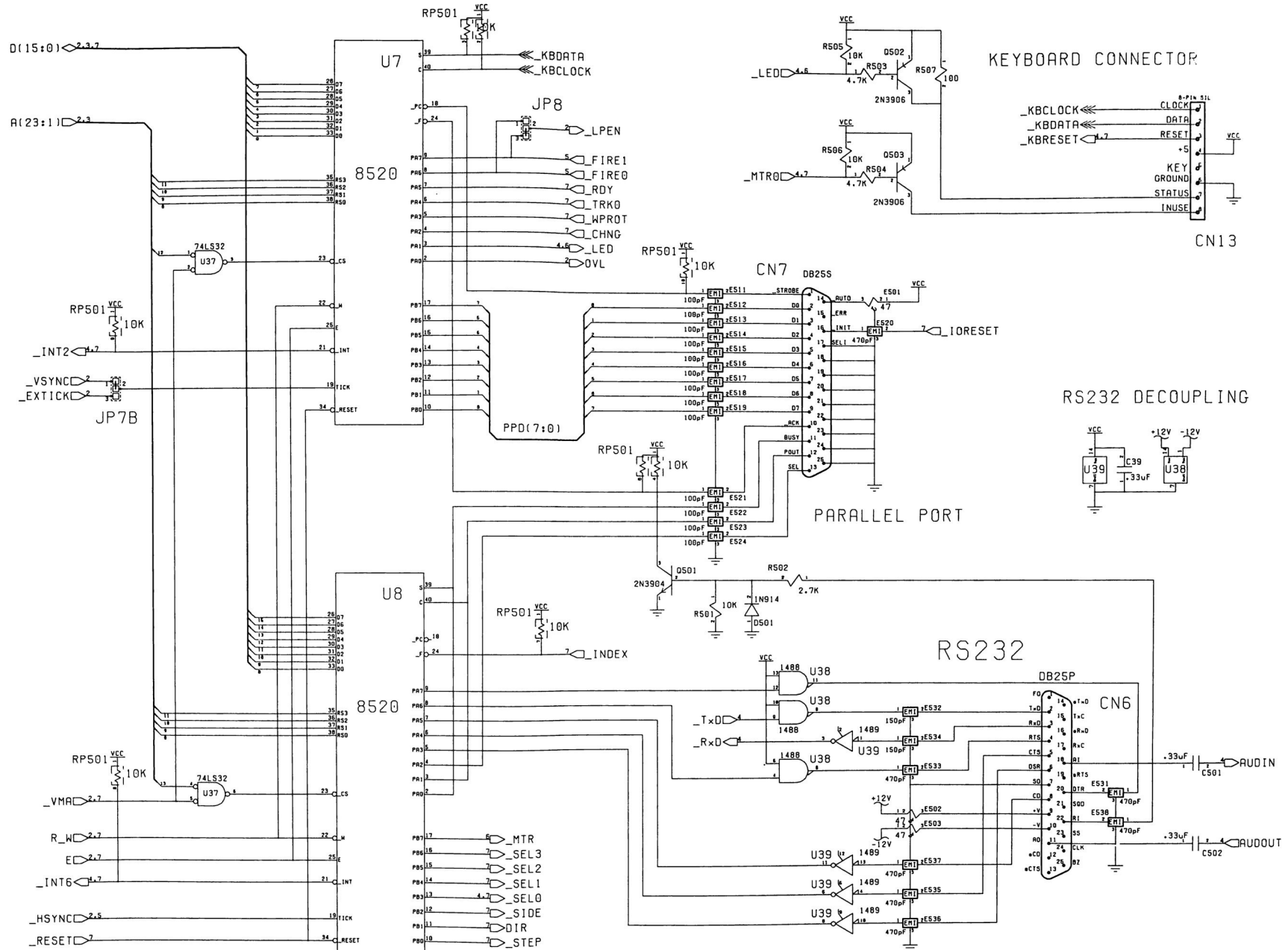

Note: E501-503 are loaded with 47 Ohm 1/2 W resistors

EXPANSION P1

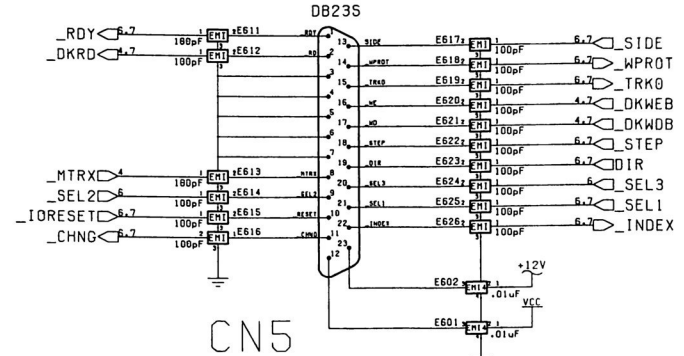
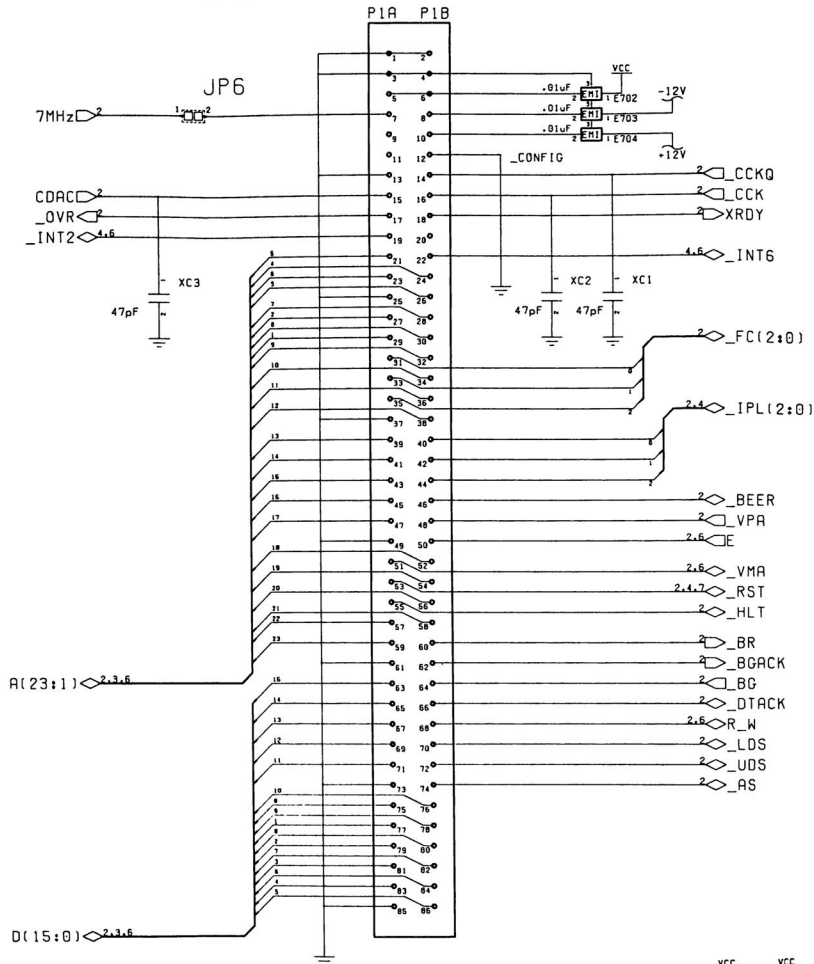

EXTERNAL FLOPPY

CN11

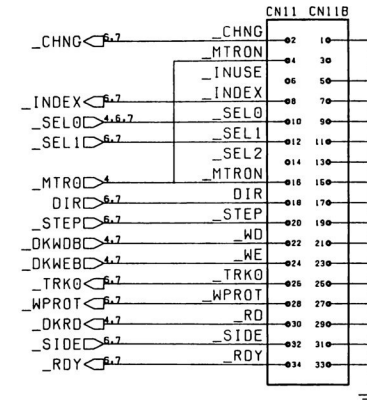

INTERNAL FLOPPY

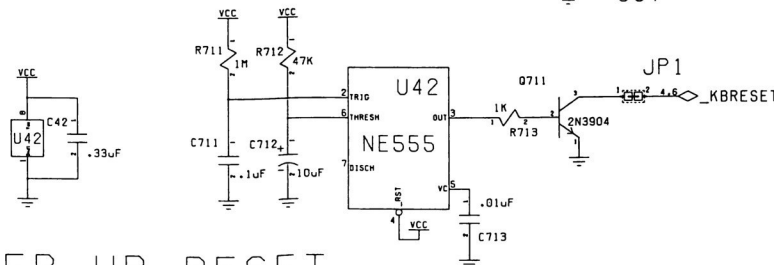
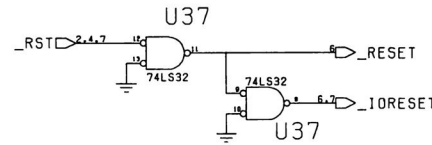

POWER UP RESET

# POWER INPUT

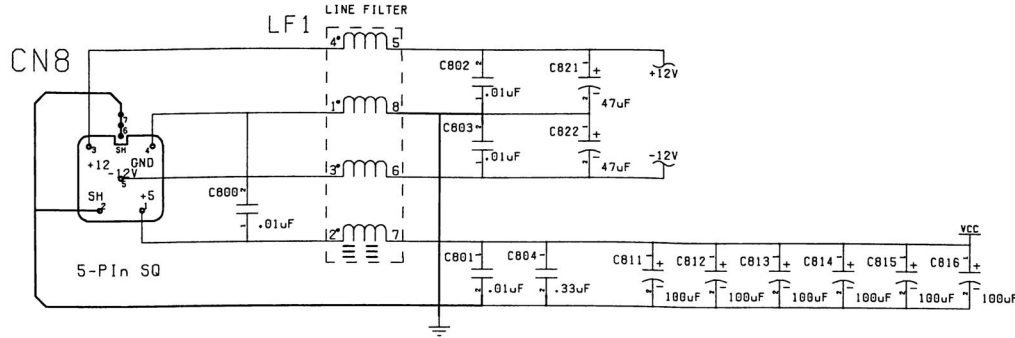

NOTE: HEAVY LINES INDICATE A SINGLE POINT CONNECTION

# FLOPPY POWER

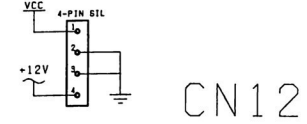

Note: Some drives are +5 only...

# SPARES

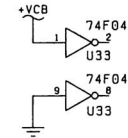

# GROUNDING HOLES, &c.

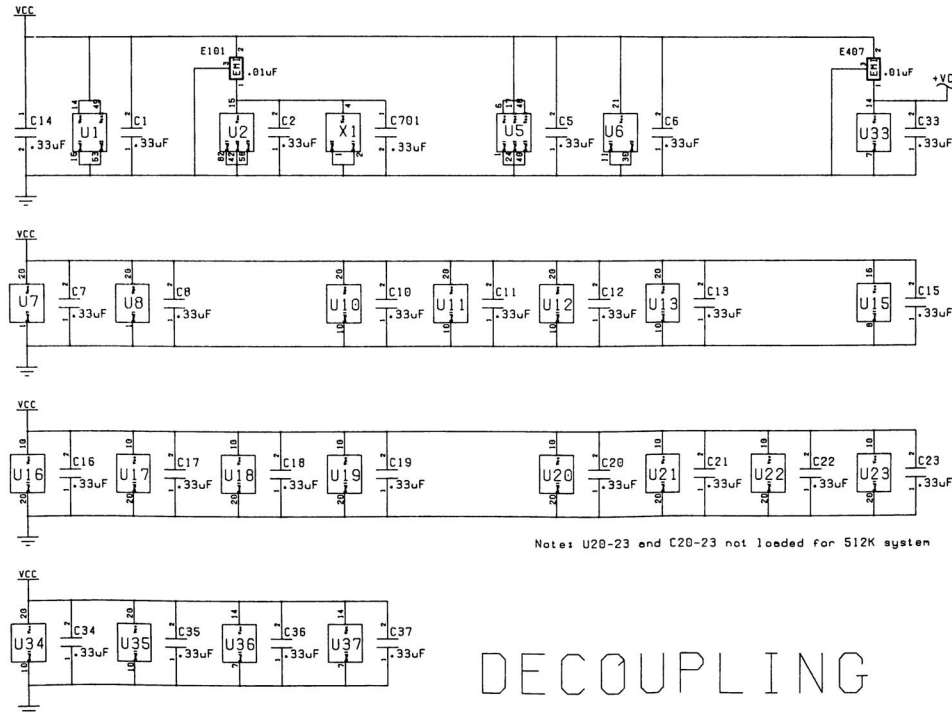
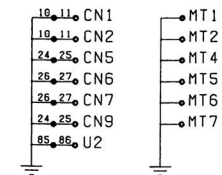

# DECOUPLING

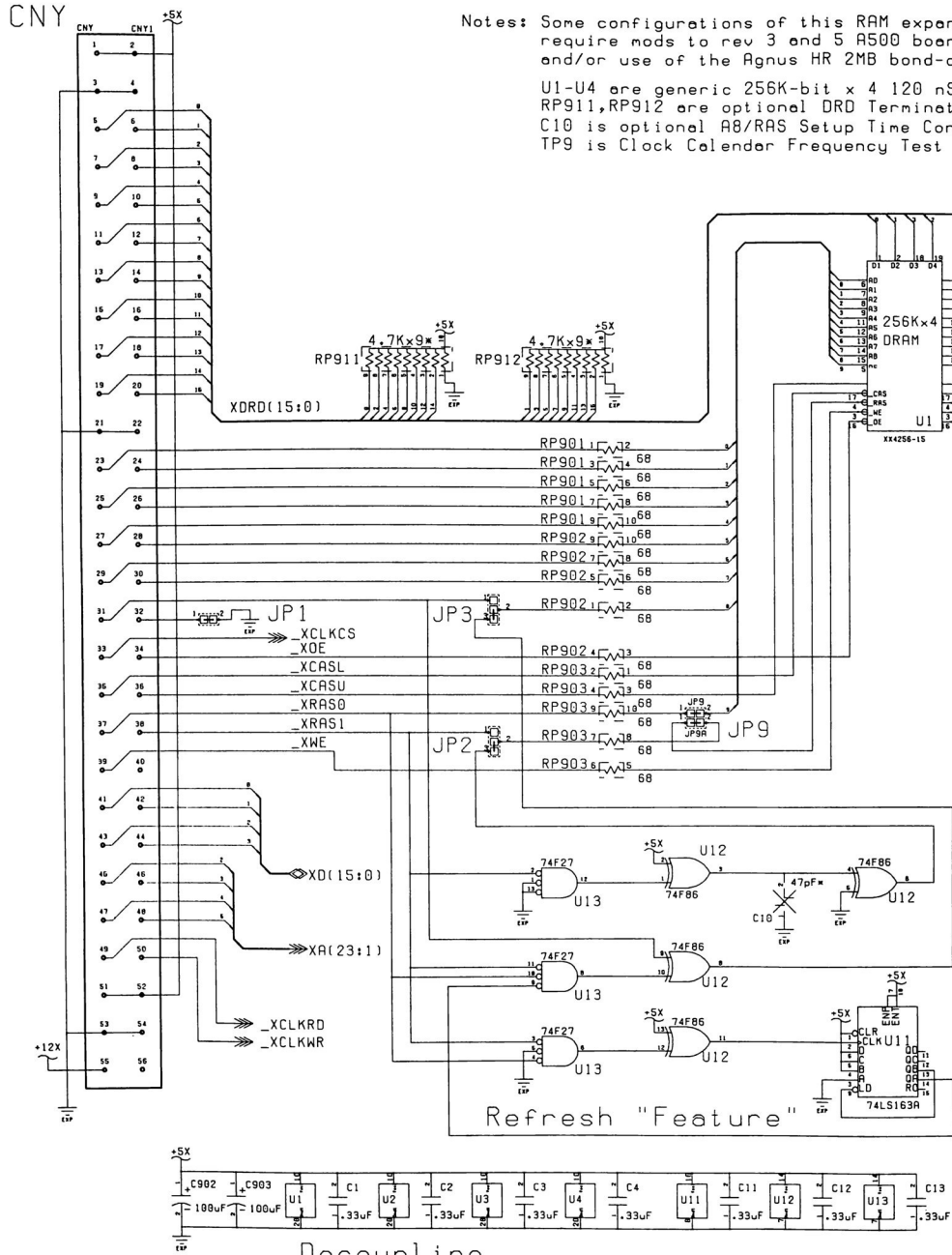

Notes: Some configurations of this RAM expansion require mods to rev 3 and 5 A500 boards and/or use of the Agnus HR 2MB bond-out.  
U1-U4 are generic 256K-bit x 4 120 nS DRAM  
RP911,RP912 are optional DRD Termination  
C10 is optional A8/RAS Setup Time Control  
TP9 is Clock Calendar Frequency Test Point

ECO History

ECO NUMBER	DESCRIPTION	DATE

Configuration Options

	A	B
on-board	512K	2M
on A501	512K	-
U1-U4	256Kx4	1Mx4
Agnus	Fat/HR	HR (2M)
JP1	1-2	-
JP9	1-2,1-2	1-1,2-2

Real Time Clock

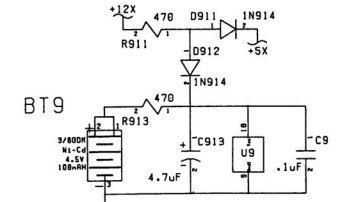
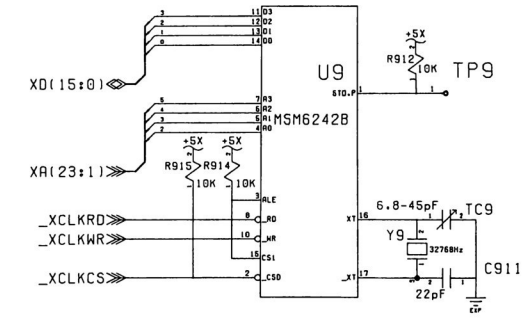

Real Time Power

Decoupling...

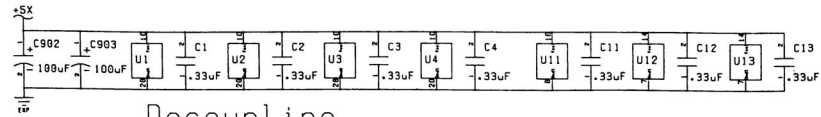

## **Input/Output Connectors**

This section lists pin assignments for several input/output connectors on the Amiga. The information in this section is highly technical and is intended only for those expert in connecting external devices to computers. You do not need this information if you use a cable specifically designed for use with the Amiga and the add-on you want to connect.

For information about connectors not described in this section, see the *Amiga Hardware Manual*.

*If you attach peripherals with cables other than those designed for use with the Amiga, note: some pins on Amiga connectors provide power outputs and non-standard signals. Attempting to use cables not wired specifically for the Amiga may cause damage to the Amiga or to the equipment you connect.* The descriptions below include specific warnings for each connector. For more information about connecting add-ons, consult your Amiga dealer.

In the descriptions that follow, an asterisk (\*) at the end of a signal name indicates a signal that is active low.

## Serial Connector

In the following table, the second column from the left gives the Amiga pin assignments. The third and fourth columns from the left give pin assignments for other commonly used connections; the information in these two columns is given for comparison only.

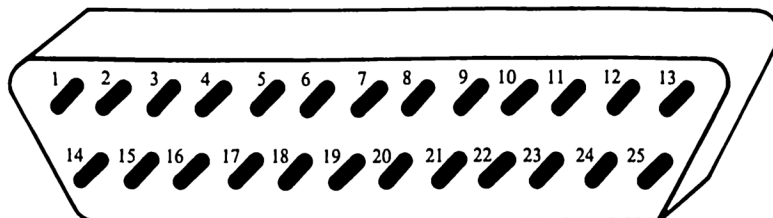

**WARNING:** Pins 9 and 10 on the Amiga serial connector are used for external power. Connect these pins **ONLY** if power from them is required by the external device. The table lists the power provided by each of these pins.

Pin	Amiga 500	RS232	HAYES®	Description
1	GND	GND	GND	FRAME GROUND
2	TXD	TXD	TXD	TRANSMIT DATA
3	RXD	RXD	RXD	RECEIVE DATA
4	RTS	RTS		REQUEST TO SEND
5	CTS	CTS	CTS	CLEAR TO SEND
6	DSR	DSR	DSR	DATA SET READY
7	GND	GND	GND	SYSTEM GROUND
8	DCD	DCD	DCD	CARRIER DETECT
9	+ 12V			+ 12 VOLT CARRIER
10	- 12V			- 12 VOLT CARRIER
11	AUDO			AUDIO OUT OF AMIGA
12		S.SD	SI	SPEED INDICATE
13		S.CTS		
14		S.TXD		
15		TXC		
16		S.RXD		
17		RXC		
18	AUDI			AUDIO INTO AMIGA
19		S.RTS		
20	DTR	DTR	DTR	DATA TERMINAL READY
21		SQD		
22	RI	RI	RI	RING INDICATOR
23		SS		
24		TXC1		
25				

## A500 Parallel Connector

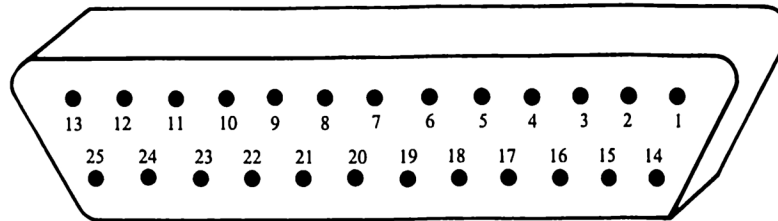

**WARNING:** Pin 14 on the Amiga parallel connector supplies +5 volts of power. Connect this pin **ONLY** if the power from it is required by the external device. **NEVER** connect this pin to an output of an external device or to a signal ground. Pins 17-25 are for grounding signals. **DO NOT** connect these pins directly to a shield ground.

Pin	Name	Description
1	STROBE*	STROBE
2	D0	DATA BIT 0 (Least sign. bit)
3	D1	DATA BIT 1
4	D2	DATA BIT 2
5	D3	DATA BIT 3
6	D4	DATA BIT 4
7	D5	DATA BIT 5
8	D6	DATA BIT 6
9	D7	DATA BIT 7
10	ACK*	ACKNOWLEDGE
11	BUSY	BUSY
12	POUT	PAPER OUT
13	SEL	SELECT
14	+5V PULLUP	+5 VOLTS POWER (100 mA)
15	NC	NO CONNECTION
16	RESET*	RESET
17	GND	SIGNAL GROUND
18	GND	SIGNAL GROUND
19	GND	SIGNAL GROUND
20	GND	SIGNAL GROUND
21	GND	SIGNAL GROUND
22	GND	SIGNAL GROUND
23	GND	SIGNAL GROUND
24	GND	SIGNAL GROUND
25	GND	SIGNAL GROUND

## RGB Monitor Connector

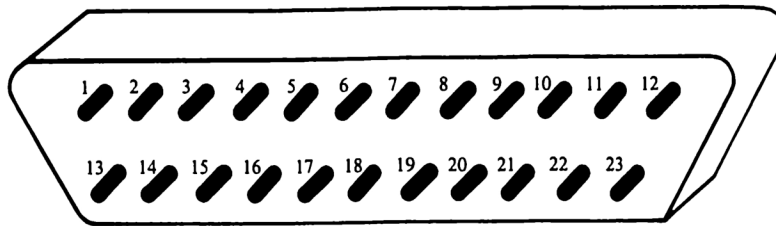

**WARNING:** Pins 21, 22, and 23 on the RGB monitor connector are used for external power. Connect these pins **ONLY** if power from them is required by the external device. The table lists the power provided by each of these pins.

Pin	Name	Description
1	XCLK*	EXTERNAL CLOCK
2	XCLKEN*	EXTERNAL CLOCK ENABLE
3	RED	ANALOG RED
4	GREEN	ANALOG GREEN
5	BLUE	ANALOG BLUE
6	DI	DIGITAL INTENSITY
7	DB	DIGITAL BLUE
8	DG	DIGITAL GREEN
9	DR	DIGITAL RED
10	CSYNC*	COMPOSITE SYNC
11	HSYNC*	HORIZONTAL SYNC
12	VSYNC*	VERTICAL SYNC
13	GNDRTN	RETURN FOR XCLKEN*
14	ZD*	ZERO DETECT
15	C1*	CLOCK OUT
16	GND	GROUND
17	GND	GROUND
18	GND	GROUND
19	GND	GROUND
20	GND	GROUND
21	- 12V	- 12 VOLTS POWER (50 mA)
22	+ 12V	+ 12 VOLTS POWER (100 mA)
23	+ 5V	+ 5 VOLTS POWER (100 mA)

## Mouse/Game Controller Connectors

There are connectors labeled "JOY1" and "JOY2" on the back of the Amiga 500. If you use a mouse to control the Workbench, you must attach it to connector JOY 1. You can attach joystick controllers to either of the connectors. To use a light pen, you must attach it to connector 1. The following tables describe mouse, game controller, and light pen connections.

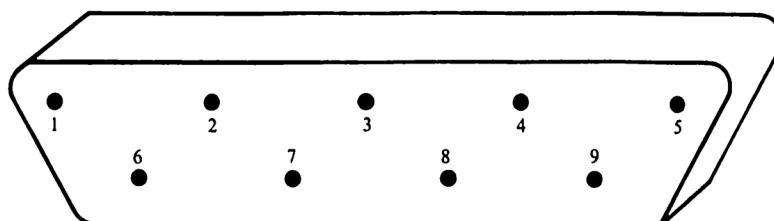

**WARNING: Pin 7 on each of these connectors supplies +5 volts of power. Connect this pin ONLY if power from it is required by the external device.**

### Connectors 1 and 2: Mouse Connections

Pin	Name	Description
1	MOUSE V	MOUSE VERTICAL
2	MOUSE H	MOUSE HORIZONTAL
3	MOUSE VQ	VERTICAL QUADRATURE
4	MOUSE HQ	HORIZONTAL QUADRATURE
5	MOUSE BUTTON 2	MOUSE BUTTON 2
6	MOUSE BUTTON 1	MOUSE BUTTON 1
7	+5V	+ 5 VOLTS POWER (100 mA)
8	GND	GROUND
9	MOUSE BUTTON 3	MOUSE BUTTON 3

## Connectors 1 and 2: Game Controller

Pin	Name	Description
1	FORWARD*	CONTROLLER FORWARD
2	BACK*	CONTROLLER BACK
3	LEFT*	CONTROLLER LEFT
4	RIGHT*	CONTROLLER RIGHT
5	POT X	HORIZONTAL POTENTIOMETER
6	FIRE*	CONTROLLER FIRE
7	+5V	+ 5 VOLTS POWER (100 mA)
8	GND	GROUND
9	POT Y	VERTICAL POTENTIOMETER

## Connector 2: Light Pen Connection

Pin	Name	Description
1		
2		
3		
4		
5	LIGHT PEN PRESS	LIGHT PEN TOUCHED TO SCREEN
6	LIGHT PEN*	CAPTURE BEAM POSITION
7	+5V	+ 5 VOLTS POWER (100 mA)
8	GND	GROUND
9		

## External Disk Connector

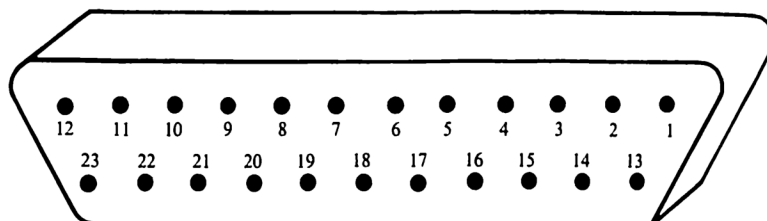

Pin	Name	Description
1	/RDY	Disk Ready—Active Low
2	/DKRD	Disk Ready Data—Active Low
3-7	GND	Ground
8	/MTRXD	Disk Motor Control—Active Low
9	/SEL2B	Select Drive 2—Active Low
10	/DRESB	Disk RESET—Active Low
11	/CHNG	Disk has been Removed from Drive— Latched Low
12	+5	5 VDC Supply
13	/SIDEB	Select Disk Side—0 = Upper 1 = Lower
14	/WPRO	Disk is Write Protected—Active Low
15	/TKO	Drive Head Position over Track 0—Active Low
16	/DKWE	Disk Write Enable—Active Low
17	/DKWD	Disk Write Data—Active Low
18	/STEPB	Step the Head—Pulse, First Low then High
19	DIRB	Select Head Direction—0 = Inner 1 = Outer
20	/SEL3B	Select Drive 3—Active Low
21	/SEL1B	Select Drive 1—Active Low
22	/INDEX	Disk Index Pulse—Active Low
23	+12	12 VDC Supply

## Power Supply Connector

Pin	Name
1	+5Vdc @ 4.3A
2	SHIELD GROUND
3	+12Vdc @ 1.0A
4	SIGNAL GROUND
5	-12Vdc @ .1A

**86-Pin Connector**

<b>Pin</b>	<b>Name</b>	<b>Pin</b>	<b>Name</b>
1	gnd	44	IPL2*
2	gnd	45	A16
3	gnd	46	BERR*
4	gnd	47	A17
5	+5	48	VPA*
6	+5	49	gnd
7	exp	50	E
8	-12	51	VMA*
9	exp	52	A18
10	+12	53	RES*
11	exp	54	A19
12	CONFIG*	55	HLT*
13	gnd	56	A20
14	C3*	57	A22
15	CDAC	58	A21
16	C1*	59	A23
17	OVR*	60	BR*
18	XRDY	61	gnd
19	INT2*	62	BGACK*
20	PALOPE*	63	PD15
21	A5	64	BG*
22	INT6*	65	PD14
23	A6	66	DTACK*
24	A4	67	PD13
25	gnd	68	PRW*
26	A3	69	PD12
27	A2	70	LDS*
28	A7	71	PD11
29	A1	72	UDS*
30	A8	73	gnd
31	FC0	74	AS*
32	A9	75	PD0
33	FC1	76	PD10
34	A10	77	PD1
35	FC2	78	PD9
36	A11	79	PD2
37	gnd	80	PD8
38	A12	81	PD3
39	A13	82	PD7
40	IPL0*	83	PD4
41	A14	84	PD6
42	IPL1*	85	gnd
43	A15	86	PD5



Computer Systems Division  
1200 Wilson Drive  
West Chester, PA 19380